



TECHNICAL GUIDE

R-410A
ZT SERIES
15 - 23 TON
60 Hertz

Description

YORK® ZT Series Sunline™ Ultra High Efficiency units are convertible single package ultra high efficiency rooftops. All models have independent refrigeration circuits for efficient part load operation.

Although the units are primarily designed for curb mounting on a roof, they can also be mounted at ground level or set on steel beams above a finished roof.

All ZT units are self-contained and assembled on rigid full perimeter base rails allowing for overhead rigging. Every unit is completely charged, wired, piped, and tested at the factory to provide a quick and easy field installation.

All models (including those with an economizer) are convertible between bottom and horizontal duct connections.

ZT units are available in the following configurations: cooling only, cooling with electric heat, and cooling with gas heat. Electric heaters are available as field-installed accessory only.



Tested in accordance with:



ZT Shown

Table of contents

Description	1
Product highlights	2
Component location	3
Nomenclature	4
Guide specifications	12
Physical data	15
Capacity performance	17
Airflow performance	33
Sound Performance	40
Electrical data	41
Weights and dimensions	63
Unit dimensions	65

Product highlights

- Smart Equipment™ Controls: streamlines commissioning, integration, and service
- Two independent refrigeration circuits for built-in system redundancy and reliability
- Three stages of cooling in the 15 to 17.5 ton units and four stages of cooling in the 20 and 23 ton units to meet advanced building code requirements
- Ultra-high efficiency in the original large Sunline™ footprint to facilitate a direct upgrade path
- Optional MagnaDry reheat system
- IntelliSpeed variable frequency drive as standard
- Advanced ECM outdoor motors
- Evaporator coils with sine wave fine geometry for increased unit efficiency
- Balanced heating
- Convertible airflow design
- Safety monitoring
- Low ambient control
- Anti-short cycle protection
- Fan delays
- Nuisance trip protection and three strikes
- Full perimeter base rails
- Easy installation
- IntelliSpeed or VAV fan control provide a wide range of indoor airflows

Component location

The following figures show the ZT unit. Click on the callouts for more detailed descriptions of the components.

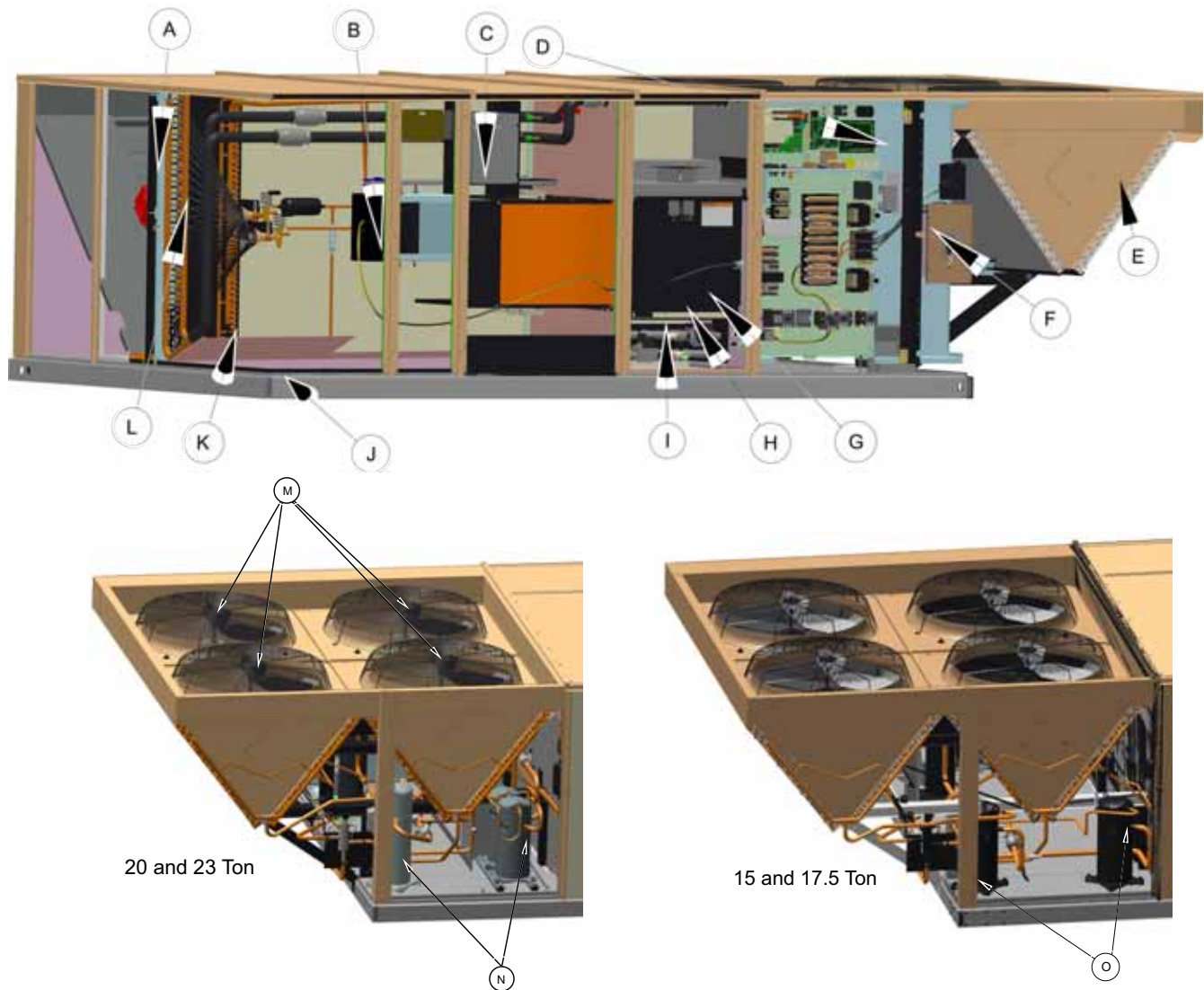

Component location table

Item	Description
A	Filter access, 2-inch or 4-inch filter options
B	Premium efficiency belt-drive blower motor
C	Variable frequency drive
D	Smart Equipment™ supply fan controls with IntelliSpeed™
E	Copper tube/aluminum fin condenser coils
F	Disconnect location, optional disconnection switch
G	Intelligent control board for safe and efficient operation
H	Two stage gas heating to maintain a warm, comfortable temperature
I	20-gauge aluminized steel tubular heat exchanger for long life. Stainless steel option
J	Full perimeter base rails with holes for overhead rigging
K	Drain pan with 1-inch NPT connection
L	High efficiency sine wave fin evaporator coil
M	ECM outdoor fan motor
N	20 and 23 ton units: two speed compressor on circuit 2 and uneven tandem compressors on circuit 1
O	15 and 17.5 ton units: two speed compressors on both circuit 2 and circuit 1

Nomenclature

15-23 Ton York® Model Number Nomenclature

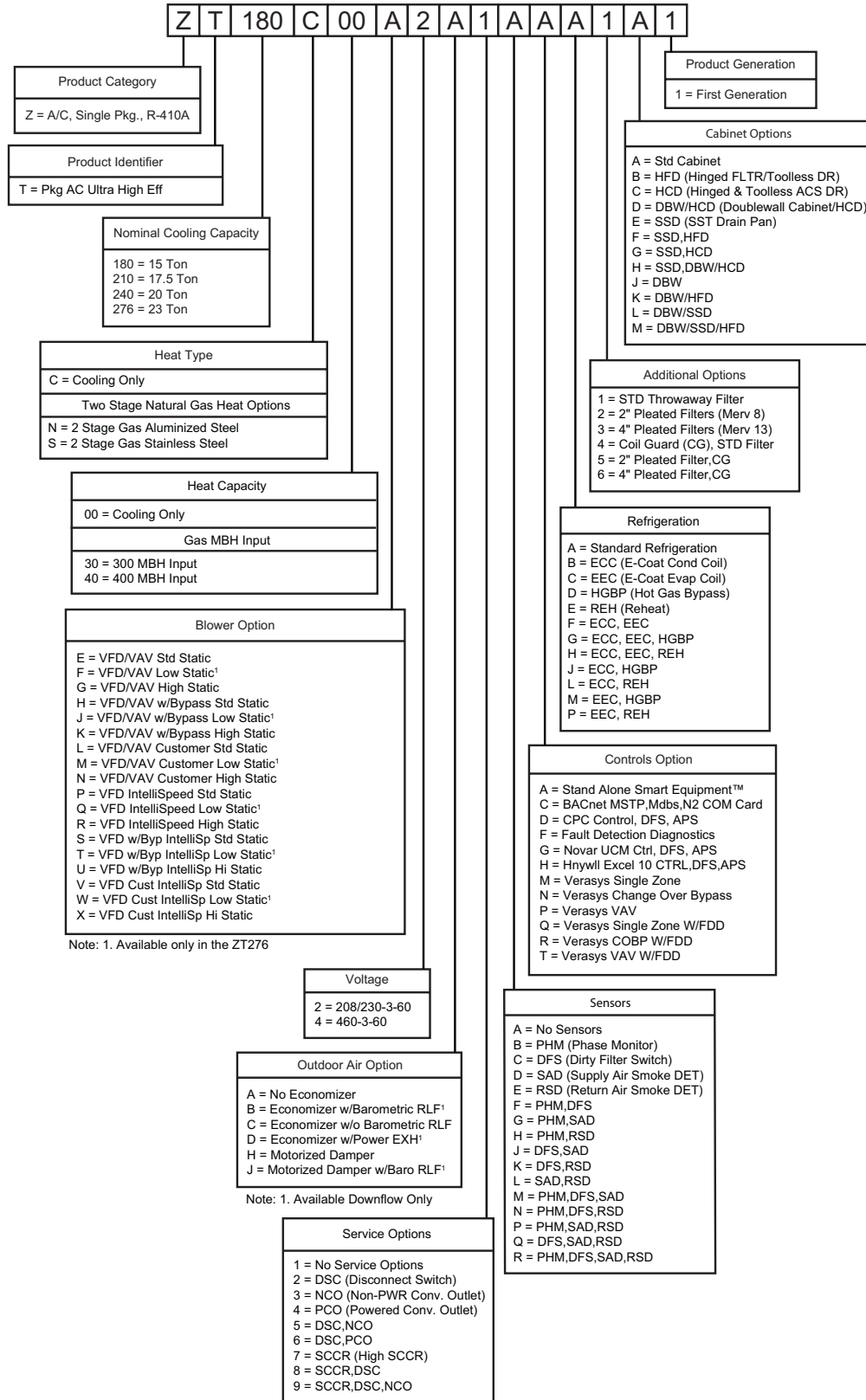

Standard features

This section describes the standard features for ultra-high efficiency 15 to 23 ton units.

Ultra-high efficiency

Ultra-high efficiency units reach as high as 18.0 IEER and 12.2 EER. Gas and electric units have electronic spark ignition and power vented combustion with steady state efficiencies of 80%. These efficiencies exceed all legislated minimum levels and provide low operating costs.

Two independent refrigeration circuits

Two independent refrigerant circuits provide multiple stages of cooling operation for increased efficiency and reliability. The 15 and 17.5 ton models use two 2-speed compressors, one on each circuit, for 3 total stages of cooling. The 20 and 23 ton models use a single 2-speed compressor on one circuit with an uneven tandem set on the other circuit for 4 total stages of cooling.

Optional MagnaDry™ dehumidification system

Units optioned with reheat coils provide superior dehumidification at a wide range of outdoor temperatures. This system provides comfort without over-cooling the space.



Indoor motors

Units come from the factory with premium efficiency, inverter rated, indoor motors.

Variable frequency drive

Factory-installed variable frequency drives (VFD) provide higher efficiency through both IntelliSpeed and variable air volume (VAV) operation. All factory-installed VFDs come with a 5-year manufacturer warranty and provide ease of commissioning with operation through the standard Smart Equipment™ control board and soft start capabilities for improved motor and belt life.



ECM outdoor motors

Units come from the factory with long lasting, high efficiency ECM motors.



Evaporator coil technology

15 to 23 ton Ultra High Efficiency units use new sine wave fin geometry in a copper tube/aluminum fin evaporator coil for increased unit efficiency.

Balanced heating

• Gas heat

All gas heat units are built with two heating sections for two equal stages of capacity control. Each section includes a durable heat exchanger with aluminized steel or optional stainless steel tubes, a redundant gas valve, spark ignition, power venting, an ignition module for 100% shut-off, and all of the safety controls required to meet the latest ANSI standards.

The gas supply piping can be routed into the heating compartment through a hole in the base pan of the unit or through a knockout in the piping panel on the front of the unit.

• Electric heat

All electric heat models (field-installed accessory only) are wired for a single power source and include a bank of nickel chromium elements mounted at the discharge of the supply air blower to provide a high velocity and uniform distribution of air across the heating elements. Every element is fully protected against excessive current and temperature by fuses and two thermal limit switches.

The power supply wiring can be routed into the control box through a threaded pipe connection in the base pan of the unit or through a knockout in the wiring panel on the front of the unit.

Convertible airflow design

All models (including those with an economizer) are suitable for either bottom or horizontal duct connections. Models with factory-installed power exhaust are suitable for bottom duct connections only. For bottom duct applications, you remove the sheet metal panels from the supply and return air openings through the base of the unit. For horizontal duct applications, you replace the supply and return air panels on the rear of the unit with a side duct flange accessory.

Advanced, versatile controls

- Smart Equipment™ control boards have standardized a number of features previously available only as options or by using additional controls.
- All units are factory commissioned, configured, and run tested.
- The Smart Equipment™ control can be configured for use with a standard thermostat (easy to connect screw terminals), a zone sensor, or can be set up to communicate with multiple BAS communication protocols to integrate with building automation systems.



• On-board USB port

The Smart Equipment™ control comes standard with an on-board USB port that accepts a common flash drive. This port can be used for features like data logging, listing current and previous system faults, and backing up or updating the software version. Self-test and start up reports are also available through the USB port.

• Embedded LCD display

The board has an easy to read, built-in LCD display and easy to use navigation joystick and buttons allowing the user to quickly navigate the menus displaying unit status, options, current function, supply, return and outdoor temperatures, fault codes and other information.

⚠ CAUTION

The Smart Equipment™ control board used in this product will effectively operate the cooling system down to 0°F when this product is applied in a comfort cooling application for people. An economizer is typically included in this type of application. When applying this product for process cooling applications (computer rooms, switchgear, etc.), please call the applications department for Ducted Systems @ 1-877-874-SERV for guidance. Additional accessories may be needed for stable operation at temperatures below 30°F.

Reduced field-installed complexity

Each unit comes equipped with factory installed supply air, return air, and outdoor air temperature sensors providing key temperature readings thus reduce field installed complexity.

Safety monitoring

The control monitors the outdoor, supply, and return air temperatures and the high and low pressure switch status on the independent refrigerant circuits. On units with heating the gas valve and high temperature limit switches are monitored on gas and electric heating units. The control also monitors the voltage supplied to the unit and will protect the unit if low voltage due to a brown out, or other electrical issue occurs.

Low ambient control

An integrated low-ambient control allows units to operate in the cooling mode down to 0°F outdoor ambient without additional components or intervention. Optionally, the control board can be programmed to lockout the compressors when the outdoor air temperature is low or when free cooling is available.

Anti-short cycle protection

To aid compressor life, an anti-short cycle delay is incorporated into the standard control. Compressor reliability is further ensured by programmable minimum run times. For testing, the anti-short cycle delay can be temporarily overridden with the push of a button.

Fan delays

Fan on and fan off delays are fully programmable. Furthermore, the heating and cooling fan delay times are independent of one another. All units are programmed with default values based upon their configuration of cooling and/or heating capacity.

Nuisance trip protection and three strikes

To prevent nuisance calls, the control board uses a three times, you're out philosophy. The high, low-pressure switch, anti-freeze protection, low voltage or heating high limit must trip three times within two hours before the unit control board locks out the associated compressor. An alarm message is then displayed on the LCD screen.

Low limit control

The low limit control (LLC) prevents the supply air from dropping below a specified set point, when there is a demand for cooling during cold outside conditions. This is a programmable setpoint.

Reliability

From the beginning, all units undergo computer automated testing before they leave the factory. Units are tested for refrigerant charge and pressure, unit amperage, and 100% functionality. For the long term: all units are painted with a long lasting, powder paint that stands up over the life of the unit. The paint used has been proven by a 750-hour salt spray test.

Full perimeter base rails

The permanently attached base rails provide a solid foundation for the entire unit and protect the unit during shipment. The rails offer rigging holes so that an overhead crane can be used to place the units on a roof.

Easy installation

Gas and electric utility knockouts are supplied in the unit underside as well as the side of the unit. Utility connections can be made quickly and with a minimum amount of field labor. All units are shipped with 2-inch throw-away filters installed, unless otherwise specified.

Wide range of indoor airflows

All supply air blowers are equipped with a belt drive that can be adjusted to meet the exact requirements of the job. A high static drive option is available for applications with a higher CFM and/or static pressure requirement.

Standard factory warranty

All models include a 1-year limited warranty on the complete unit. Compressors and electric heater elements each carry a 5-year warranty. Aluminized steel (10 year) and stainless steel tubular heat exchangers carry a 15-year warranty.

Options and accessories

The following options and accessories are available as factory-installed and field-installed options.

Options and accessories

	Factory option	Field-installed
Non-electrical		
Burglar bars		✓
Coil guard	✓	✓
Hail guard		✓
Flue exhaust extension		✓
MERV 8 filter	✓	
MERV 13 filter	✓	
Side duct flange		✓
Gas piping kit		✓
High altitude kit for natural gas		✓
High altitude kit for propane		✓
Propane conversion		✓
Roof curb, 14-inch height		✓
Wooden skid		✓
Aluminized steel gas heat exchanger	✓	
Stainless steel gas heat exchanger	✓	
Stainless steel drain pan	✓	
E-Coat coil coating	✓	
Magna-Dry dehumidification option	✓	
Hot gas bypass (excludes MagnaDry optioned units)	✓	
Hinged and toolless access panels	✓	
Double wall	✓	
Electrical		
High static indoor blower motor	✓	✓
Disconnect switch	✓	
Convenience outlet - (Non-powered or powered)	✓	
Phase monitor	✓	
Electric heat options		✓
Fresh air		
Motorized damper	✓	✓
Low leak economizer	✓	✓
Single or dual enthalpy control		✓
Economizer hood kit	✓	✓
Barometric relief damper	✓	✓
Power exhaust	✓	✓
Controls		
Air proving switch		✓
CO ² sensor		✓
Dirty air filter switch	✓	✓
Smoke detectors for supply and return air configurations	✓	✓
CPC BAS control	✓	
Honeywell BAS control	✓	
Novar® BAS control	✓	
MAP (Mobile Access Portal) Gateway for use with Smart Equipment™ control		✓
Verasys	✓	✓

Factory and field-installed options

YORK® offers several factory and field-installed options for the Large Sunline™ series.

Down flow and end return economizers with barometric relief and fresh air hood

Factory or field-installed option

All units offer a variety of optional factory-installed or field-installed economizers that are shipped, installed and wired with low leak dampers designed to meet ASHRAE 90.1, AMCA 511 Class 1A damper, and the International Energy Conservation Code (IECC) certification requirements by achieving leakage rates of 3 CFM/sq. ft. at 1-inch of static pressure.

Each economizer goes through a rigorous 60,000 cycle test. Dry bulb, single enthalpy, and dual enthalpy (with field installed kit) can be selected. The economizer has spring return, fully modulating damper actuators and is capable of introducing up to 100% outdoor air. As the outdoor air intake dampers open, the return air dampers close. The changeover from mechanical refrigeration to economizer operation is regulated by the outdoor air dry bulb temperature or the outdoor air enthalpy input. The installer needs only to assemble the outdoor air hood, attach the enthalpy control the hood and mount the hood to the unit (hood and control are provided).

Single or dual enthalpy control accessories

Field-installed option

The single enthalpy or dual enthalpy control kits provide sensors to monitor outdoor air and/or return air humidity and temperature for true enthalpy control of the unit economizer.

Power exhaust

Factory or field-installed option

Units with an economizer are available with power exhaust. Whenever the outdoor air intake dampers are opened for free cooling, the exhaust fan is energized to prevent the conditioned space from being over-pressurized during economizer operation. The power exhaust option can only be used on bottom duct configurations.

Motorized outdoor air damper

Factory or field-installed option

The motorized outdoor air damper includes a slide-in / plug-in damper assembly with a 2-position, spring return motor actuator which opens to a preset position whenever the supply air blower is operating and drives fully closed when the blower motor shuts down. The damper has a range of 0% to 100% outdoor air entry.

Barometric relief damper

Factory or field-installed option

This damper option can be used to relieve internal building air pressure on units with an economizer or motorized damper without a power exhaust. This accessory includes a rain hood, a bird screen, and a fully assembled damper.

Alternate indoor blower motor

Factory or field-installed option

For applications with high static restrictions, units are offered with optional indoor motors that provide higher static output and/or higher airflow, depending upon the installer's needs.

Aluminized steel gas heat exchanger

Factory option

The standard gas heat exchanger option for applications in non-corrosive environments.

Stainless steel gas heat exchanger

Factory option

The gas heat exchanger option for applications in corrosive environments. This option provides a full stainless steel heat exchanger assembly.

Stainless steel drain pan

Factory option

An optional rust-proof stainless steel drain pan is available to provide years of trouble-free operation in corrosive environments.

Electric heaters

Field-installed option

Electric heat is available as a field-installed option with a range from 18 to 72 kW in all voltage options of the base units. All heaters are intended for single point power. As a field installed option, the electric heater is installed in a base cooling only unit through an adapter panel for easy installation. The required hardware and connectors are included with the heaters.

Disconnect switch

Factory option

For gas heat units and cooling units with electric heat, a HACR breaker sized to the unit is provided. For cooling only units, a switch sized to the largest electric heat available for the particular unit is provided.

Convenience outlet

Factory option

Non-powered and powered convenience outlets are available. This option locates a 120V single-phase GFCI outlet with a cover on the exterior of the unit. The non-powered option requires the installer to provide the 120V single-phase power source and wiring. The powered option is powered by a stepdown transformer in the unit.

Smoke detectors

Factory or field-installed option

The smoke detectors stop operation of the unit and provide a fault message to the control board. Smoke detectors are available for both the supply and/or return air configurations.



Factory-installed smoke detectors may be subjected to extreme temperatures during off times due to outside air infiltration. These smoke detectors have an operational limit of -4°F to 158°F. Smoke detectors installed in areas that could be outside this range will have to be relocated to prevent false alarms.

CO₂ sensor

Field-installed option

This kit senses CO₂ levels and automatically overrides the economizer when levels rise above the preset limits.

Filters

Factory or field-installed option

2-inch Pleated MERV 8 or 4-inch Pleated MERV 13 are available to meet LEED requirements. A 2-inch throwaway is shipped as standard.

Coil guard

Factory or field-installed option

Customers can purchase a coil guard to protect the condenser coil from damage. Additionally, this kit stops animals and foreign objects from entering the space between the inner condenser coil and the main cabinet. This is not a hail guard kit.

Hail guard

Field-installed option

This kit includes a sloped hood or tight metal grate that is installed over the outside condenser coil and prevents damage to the coil fins from hail strikes.

Dirty filter switch

Factory or field-installed option

This option/kit includes a differential pressure switch that energizes the fault light on the unit thermostat, indicating that there is an abnormally high pressure drop across the filters.

E-Coat evaporator and condenser

Factory option

The evaporator and/or condenser coils are coated with an epoxy polymer coating to protect against corrosion.

Flue exhaust extension kit

Field-installed option

In locations with wind or weather conditions which may interfere with proper exhausting of furnace combustion products, this kit can be installed to prevent the flue exhaust from entering nearby fresh air intakes.

Gas heat high altitude kit

Field-installed option

This kit converts a gas heat unit to operate at high altitudes from 2,000 to 6,000 feet. Conversion kits are available for natural gas and propane.

Gas heat propane conversion kit

Field-installed option

This kit converts a gas-fired heater from natural gas to propane. It contains the main burner orifices and gas valve replacement springs.

Gas piping kit

Field-installed option

Contains pipe nipples, fittings and gas cock required for gas supply connection with external shut off.

Roof curbs

Field-installed option

The roof curbs have insulated decks and are shipped disassembled. For applications with security concerns, burglar bars are available for the duct openings of the roof curbs.

Burglar bars

Field-installed option

Mount in the supply and return openings to prevent entry into the duct work.

Control options

The following sections describe the control options.

Smart Equipment™ control with communication option

The communication option for the Smart Equipment™ control is a factory installed add-on card to expand the capabilities with a gateway to BACnet MS/TP (programmable to Modbus or N2 protocols).

Novar® BAS control

Factory option

The Novar® building automation system controller is factory installed. Includes supply air sensor, return air sensor, dirty filter indicator switch, and air proving switch.

CPC BAS control

Factory option only

The Computer Process Controls Model 810-3060 ARTC Advanced Rooftop building automation system controller is factory installed. Includes supply air sensor, return air sensor, with optional dirty filter indicator switch and air proving switch.

Honeywell BAS control

Factory option

The Honeywell W7750C building automation system controller is factory installed. Includes air supply sensor, return air sensor, with optional dirty filter indicator switch, and air proving switch.

Verasys

Factory or field-installed option

Verasys provides a simple user experience with configurable self-recognizing controllers without the need for any additional tools. Verasys creates enhanced integration of HVACR equipment, zoning, and controls. Contractors are able to offer a complete bundled solution of equipment and controls to serve the light commercial market.

Guide specifications

General

Units shall be manufactured by Johnson Controls Ducted Systems in an ISO 9001 certified facility.

York's Large Sunline ZT units are convertible single package units. ZT models have dual independent refrigerant circuits for efficient part load operation and maximum comfort control. Although the units are primarily designed for curb mounting on a roof, they can also be slab-mounted at ground level or set on steel beams above a finished roof. All units are self-contained and assembled on full perimeter base rails with holes in the four corners for overhead rigging. Every unit is completely piped, wired, charged and tested at the factory to simplify the field installation and to provide years of dependable operation. All models (including those with an economizer) are suitable for either bottom or horizontal duct connections. Models with power exhaust are suitable for bottom duct connections only. For bottom duct, remove the sheet metal panels from the supply and return air openings through the base of the unit. For horizontal duct, replace the supply and return air panels on the rear of the unit with a side duct flange accessory. All supply air blowers are equipped with a belt drive that can be adjusted to meet the exact requirements of the job. A high static drive option is available for applications with a higher CFM and/or static pressure requirement.

ZT models have 4 condenser fan motors. All compressors include crankcase heat and internal pressure relief. Every refrigerant circuit includes an expansion valve, a liquid line filter-drier, a discharge line high pressure switch and a suction line with a freeze-stat and low pressure/loss of charge switch. The unit control circuit includes a 75 VA transformer, a 24-volt circuit breaker and a relay board with two compressor lockout circuits, a terminal strip for thermostat wiring, plus an additional set of pin connectors to simplify the interface of additional field controls. All units have long lasting powder paint cabinets with 750 hour salt spray test approval under ASTM-B117 procedures. All models are CSA approved. All models include a 1-year limited warranty on the complete unit. Compressors carry an additional 4-year warranty. Aluminized steel tubular heat exchangers carry an additional 9-year warranty.

Description

Units shall be factory assembled, single packaged, designed for outdoor installation. All models have electric cooling with optional factory installed gas heat or field installed electric heat. They shall have built-in field convertible duct connections for down discharge supply/return or horizontal discharge supply/return, and be available with factory installed options or field installed accessories. The units shall be factory wired, piped, charged with R-410A refrigerant and factory tested prior to shipment. All unit wiring shall be both numbered and color coded. All units shall be manufactured in a facility certified to ISO 9001 standards and the cooling performance shall be rated in accordance with DOE and AHRI test procedures. Units shall be CSA listed, classified to ANSIZ21.47 standards, UL 1995/CAN/CSA No. 236-M90 conditions.

Unit cabinet

Unit cabinet shall be constructed of galvanized steel, with exterior surfaces coated with a non-chalking, powdered paint finish, certified at 750 hours salt spray test per ASTM-B117 standards. Indoor blower section shall be insulated with a minimum 1/2" thick insulation, coated on the airside. Aluminum foil faced insulation shall be used in the furnace compartment and be fastened with ridged fasteners to prevent insulation from entering the air stream. Cabinet panels shall be "large" size, easily removable for servicing and maintenance. Full perimeter base rails shall be provided to assure reliable transit of equipment, overhead rigging and proper sealing on roof curb applications. Disposable 2" filters shall be furnished and be accessible through a removable access door, sealed airtight. Units filter track shall be designed to accommodate either 2" or 4" filters. Fan performance measuring ports shall be provided on the outside of the cabinet to allow accurate air measurements of evaporator fan performance without removing panels or creating air by-pass of the coils. Condensate pan shall be internally sloped and conform to ASHRAE 62-89 self-draining standards. Condensate connection shall be a minimum of 1" I.D. female and be a ridged mount connection. Unit shall incorporate a fixed outdoor air damper with an outdoor air intake opening covered with a bird screen and a rain hood painted to match the exterior of the unit.

Indoor (evaporator) fan assembly

Fan shall be a belt drive assembly and include an adjustable- pitch motor pulley. Job site selected (B.H.P.) brake horsepower shall not exceed the motors nameplate horsepower rating, plus the service factor. Units shall be designed not to operate above service factor. Fan wheel shall be double-inlet type with forward-curved blades, dynamically balanced to operate smoothly throughout the entire range of operation. Airflow design shall be constant air volume.

A variable air volume (VAV) option using a variable frequency drive (VFD) is available for applications requiring a constant supply duct static pressure. Units equipped for VAV shall be controlled by a duct pressure transducer with a 0 - 5" WC pressure range. The pressure transducer shall provide a 0 - 5 VDC output signal to a control board which, in turn shall provide a 2 - 10 VDC speed reference signal to the VFD. Units equipped with VFDs shall have factory-installed manual bypass as an option.

Outdoor (condenser) fan assembly

The outdoor fans shall be of the direct-driven propeller type, discharge air vertically, have aluminum blades riveted to corrosion resistant steel spider brackets and shall be dynamically balanced for smooth operation. The 4 outdoor fan motors shall be totally enclosed with permanently lubricated bearings, internally protected against overload conditions and staged independently.

Refrigerant components

Compressors:

- a. 15 and 17.5 ton units shall use two 2-stage scroll compressors internally protected with high pressure relief and over temperature protection.
- b. 20 and 23 ton units shall use one 2-stage scroll compressor and one tandem set of scroll compressors that are internally protected with high pressure relief and over temperature protection.
- c. Shall have internal spring isolation and sound muffling to minimize vibration and noise, and be externally isolated on a dedicated, independent mounting.

Coils:

- a. Evaporator and condenser coils shall have aluminum plate fins mechanically bonded to seamless internally enhanced copper tubes with all joints brazed. Special Phenolic coating shall be available as a factory option.
- b. Evaporator and Condenser coils shall be of the direct expansion, draw-thru, design.

Refrigerant Circuit and Refrigerant Safety Components shall include:

- a. Balance-port thermostatic expansion valve with independent circuit feed system.
- b. Filter drier/strainer to eliminate any moisture or foreign matter.
- c. Accessible service gage connections on both suction and discharge lines to charge, evacuate, and measure refrigerant pressure during any necessary servicing or troubleshooting, without losing charge.
- d. The refrigeration system shall provide at least 15° F of sub-cooling at design conditions.
- e. All models shall have two independent circuits.
- f. Hot gas bypass option shall be factory-installed on compressor #1 discharge line to provide cooling in low-load applications. HGBP shall be a standard feature on VAV models.

Unit controls

- a. Unit shall be complete with self-contained low-voltage control circuit protected by a resettable circuit breaker on the 24-volt transformer side.
- b. Unit shall incorporate a lockout circuit which provides reset capability at the space thermostat or base unit, should any of the following standard safety devices trip and shut off compressor.
- c. Loss-of-charge/Low-pressure switch.
 1. High-pressure switch.
 2. Freeze condition sensor, evaporator coil. If any of these safety devices trip, the LCD screen will display the alarm message.
- d. Unit shall incorporate "AUTO RESET" compressor over temperature, over current protection.
- e. Unit shall operate with conventional thermostat designs and have a low voltage terminal strip for easy hook-up.
- f. Unit control board shall have on-board diagnostics and fault message display.
- g. Standard controls shall include anti-short cycle and low voltage protection, and permit cooling operation down to 0 °F.
- h. Control board shall monitor each refrigerant safety switch independently.

Gas heating section - if equipped

Shall be designed with induced draft combustion with post purge logic and energy saving direct spark ignition, redundant main gas valve. Ventor wheel shall be constructed of stainless steel for corrosion resistance. The heat exchanger shall be of the tubular type, constructed of T1-40 aluminized steel for corrosion resistance and allowing minimum mixed air entering temperature of 25 °F. Burners shall be of the in-shot type, constructed of aluminum coated steel and contain air mixture adjustments. All gas piping shall enter the unit

cabinet at a single location through either the side or curb, without any field modifications. An integrated control board shall provide timed control of evaporator fan functioning and burner ignition. Heating section shall be provided with the following minimum protection:

- a. Primary and auxiliary high-temperature limit switches.
- b. Induced draft motor speed sensor.
- c. Flame roll out switch (automatic reset).
- d. Flame proving controls. Unit shall have two independent stages of capacity.

Electric heating (field-installed electric heat accessory)

Nickel chromium electric heating elements shall be provided as required by the application with 1 or 2 stage control, as required, from 18 KW to 72 KW capacities. The heating section shall have a primary limit control(s) and automatic reset to prevent the heating element system from operating at an excessive temperature. Units with Electric Heating shall be wired for a single point power supply with branch circuit fusing (where required).

Unit operating characteristics

Unit shall be capable of starting and running at 125° F outdoor temperature, exceeding maximum load criteria of AHRI Standard 340/360. The compressor, with standard controls, shall be capable of operation down to 25° F outdoor temperature. Unit shall be provided with fan time delay to prevent cold air delivery before heat exchanger warms up (Gas heat only).

Electrical requirements

All unit power wiring shall enter unit cabinet at a single factory provided location and be capable of side or bottom entry, to minimize roof penetrations and avoid unit field modifications. Separate side and bottom openings shall be provided for the control wiring.

Standard limited warranties

- Compressor 5 Years
- Heat Exchanger 10 Years
- Other Parts 1 Year

Physical data

ZT180-276 physical data

Component	Models							
	ZT180		ZT210		ZT240		ZT276	
Nominal tonnage	15		17.5		20		23	
ARI cooling performance								
Gross capacity @ ARI A point (Btu)	178000		198000		250000		275000	
ARI net capacity (Btu)	172000		192000		240000		265000	
EER	12.2 ¹ /12.0 ²		12.2 ¹ /12.0 ²		10.8/10.6 ²		10.2	
IEER with Intellispeed	18.0		17.0		16.0		15.5	
IEER with VAV	17.5		17.0		16.0		15.2	
CFM	5400		5400		6700		10000	
System power (KW)	14.20		15.86		21.98		25.60	
Refrigerant type	R-410a		R-410a		R-410a		R-410a	
Refrigerant charge (lb-oz)								
System 1	23-8		24-0		22-8		22-14	
System 2	24-0		24-8		25-0		23-10	
ARI heating performance								
Heating model	N30	N40	N30	N40	N30	N40	N30	N40
Heat input (K Btu)	300	400	300	400	300	400	300	400
Heat output (K Btu)	240	320	240	320	240	320	240	320
AFUE %	-	-	-	-	-	-	-	-
Steady state efficiency (%)	80	80	80	80	80	80	80	80
No. burners	6	8	6	8	6	8	6	8
No. stages	2	2	2	2	2	2	2	2
Temperature rise range (°F)	20-50	30-60	20-50	30-60	20-50	30-60	20-50	30-60
Gas limit setting (°F)	195	195	195	195	195	195	195	195
Gas piping connection (in.)	1	1	1	1	1	1	1	1
Dimensions (inches)								
Length	180-19/32							
Width	92							
Height	52-5/8							
Operating weight (lbs.)	2600		2730		2855		2925	
Compressors								
Type	Scroll		Scroll		Scroll		Scroll	
Quantity	2		2		3		3	
Unit capacity steps (%)	34 / 67 / 100		34 / 67 / 100		25 / 50 / 75 / 100		25 / 50 / 75 / 100	
Condenser coil data								
Face area (sq. ft.)	63.8		63.8		63.8		63.8	
Rows	2		2		2		2	
Fins per inch	20		20		20		20	
Tube diameter (in.)	3/8		3/8		3/8		3/8	
Circuitry type	Split-face		Split-face		Split-face		Split-face	
Evaporator coil data								
Face area (sq. ft.)	20.52		20		20		20.52	
Rows	4		4		4		4	
Fins per inch	14		14		14		14	
Tube diameter	3/8		3/8		3/8		3/8	
Circuitry type	Intertwined		Intertwined		Intertwined		Intertwined	
Refrigerant control	TXV		TXV		TXV		TXV	

ZT180-276 physical data (continued)

Component	Models									
	ZT180		ZT210		ZT240		ZT276			
Nominal tonnage	15		17.5		20		23			
Condenser fan data										
Quantity	4		4		4		4			
Fan diameter (in.)	24		30		30		30			
Type	Prop		Prop		Prop		Prop			
Drive type	Direct		Direct		Direct		Direct			
No. speeds	2		2		2		2			
Number of motors	4		4		4		4			
Motor HP each	1/3		1/2		1/2		1/2			
RPM	850/700		860/700		860/700		860/700			
Nominal total CFM	14000		17000		17000		17000			
Belt drive evap. fan data										
Quantity	1		1		1		1			
Fan size (in.)	18 X 15		18 X 15		18 X 15		18 X 15			
Type	Centrifugal		Centrifugal		Centrifugal		Centrifugal			
Motor sheave	1VP60	1VP60	1VP60	1VP60	1VP60	1VP60	1VP60	1VP75X	1VP75X	
Blower sheave	BK120	BK100	BK110	BK090	BK110	BK090	1B5V94	1B5V110	1B5V94	
Belt	BX81	BX75	BX78	BX75	BX78	BX75	BX78	5VX840	5VX860	
Motor HP each	5	7.5	7.5	10	7.5	10	7.5	10	15	
RPM	1750	1770	1770	1770	1770	1770	1770	1770	1770	
Frame size	184T	213T	213T	215T	213T	215T	213T	215T	254T	
Filters										
Quantity - size	4 - (16 x 25 x 2)		4 - (16 x 25 x 2)		4 - (16 x 25 x 2)		4 - (16 x 25 x 2)			
	4 - (16 x 20 x 2) ^{3,4}		4 - (16 x 20 x 2) ^{3,4}		4 - (16 x 20 x 2) ^{3,4}		4 - (16 x 20 x 2) ^{3,4}			
	4 - (16 x 25 x 4)		4 - (16 x 25 x 4)		4 - (16 x 25 x 4)		4 - (16 x 25 x 4)			
	4 - (16 x 20 x 4) ⁵		4 - (16 x 20 x 4) ⁵		4 - (16 x 20 x 4) ⁵		4 - (16 x 20 x 4) ⁵			

1. Cooling only unit or cooling unit with electric heat.
2. Cooling unit with gas heat.
3. 2 in. throwaway, standard, MERV (Minimum Efficiency Reporting Value) 3.
4. 2 in. pleated, optional, MERV 8.
5. 4 in. pleated, optional, MERV 13.

ZT180-276 unit limitations

Size (tons)	Unit voltage	Unit limitations		
		Applied voltage		Outdoor DB temp.
		Min	Max	Max (°F)
180 (15)	208/230-3-60	187	252	125
	460-3-60	432	504	125
210 (17.5)	208/230-3-60	187	252	125
	460-3-60	432	504	125
240 (20)	208/230-3-60	187	252	125
	460-3-60	432	504	125
276 (23)	208/230-3-60	187	252	125
	460-3-60	432	504	125

Capacity performance

ZT180-276 cooling capacities

ZT180 (15 ton)

Air on evaporator coil		Temperature of air on condenser coil															
CFM	WB (°F)	Total capacity ¹ (MBh)	Total input (kW) ²	Sensible capacity (MBh)						Total capacity ¹ (MBh)	Total input (kW) ²	Sensible capacity (MBh)					
				Return dry bulb (°F)								Return dry bulb (°F)					
				90	85	80	75	70	65			90	85	80	75	70	65
				75°F						85°F							
3750	77	202.3	9.3	89.9	73.7	57.4	-	-	-	197.2	10.9	86.9	70.4	53.9	-	-	-
	72	194.6	9.4	117.7	101.5	85.2	69.0	-	-	188.4	10.8	114.3	97.8	81.3	64.8	-	-
	67	186.8	9.4	145.5	129.2	113.0	96.8	80.5	-	179.5	10.7	141.7	125.2	108.7	92.2	75.7	-
	62	172.3	9.3	172.3	144.0	130.5	114.3	98.1	81.8	165.6	10.6	165.6	146.0	127.3	110.8	94.3	77.8
4500	77	207.5	9.4	97.0	79.4	61.7	-	-	-	202.0	10.9	95.1	76.8	58.5	-	-	-
	72	199.5	9.4	126.9	109.2	91.5	73.9	-	-	192.9	10.8	124.9	106.6	88.3	70.0	-	-
	67	191.5	9.5	156.7	139.0	121.4	103.7	86.0	-	183.8	10.8	154.6	136.3	118.0	99.7	81.4	-
	62	176.6	9.4	176.6	157.8	140.1	122.5	104.8	87.2	169.6	10.6	169.6	156.5	138.2	119.9	101.6	83.3
57	181.8	9.3	181.8	173.3	155.6	138.0	120.3	102.7	172.6	10.6	172.6	164.2	145.9	127.6	109.3	91.0	
5250	77	212.6	9.4	104.2	85.1	66.0	-	-	-	206.8	11.0	103.4	83.3	63.2	-	-	-
	72	204.4	9.5	136.0	116.9	97.9	78.8	-	-	197.5	10.9	135.5	115.4	95.2	75.1	-	-
	67	196.2	9.5	167.9	148.8	129.7	110.6	91.5	-	188.2	10.8	167.6	147.5	127.3	107.2	87.1	-
	62	181.0	9.4	181.0	171.6	149.8	130.7	111.6	92.5	173.6	10.7	173.6	167.1	149.1	129.0	108.9	88.8
57	186.3	9.4	186.3	182.0	166.5	147.4	128.3	109.2	176.7	10.7	176.7	172.5	157.5	137.3	117.2	97.1	
6000	77	217.7	9.5	111.3	90.8	70.3	-	-	-	211.6	11.0	111.6	89.7	67.8	-	-	-
	72	209.3	9.6	145.2	124.7	104.2	83.7	-	-	202.0	11.0	146.1	124.1	102.2	80.3	-	-
	67	201.0	9.6	179.1	158.6	138.1	117.6	97.1	-	192.5	10.9	180.5	158.6	136.7	114.7	92.8	-
	62	185.4	9.5	185.4	185.4	159.4	138.8	118.3	97.8	177.6	10.8	177.6	177.6	160.1	138.1	116.2	94.3
57	190.7	9.4	190.7	190.7	177.3	156.8	136.3	115.8	180.8	10.7	180.8	180.8	169.0	147.1	125.2	103.2	
6750	72	213.0	9.6	151.6	130.3	109.0	87.7	-	-	205.5	11.0	153.9	130.7	107.5	84.2	-	-
	67	204.5	9.6	193.6	165.8	144.5	123.2	101.8	-	195.8	10.9	189.8	166.9	143.7	120.5	97.2	-
	62	188.6	9.5	188.6	188.6	168.4	147.1	125.8	104.5	180.7	10.8	180.7	180.7	168.3	145.0	121.8	98.6
	57	194.1	9.5	194.1	194.1	186.8	165.5	144.2	122.9	183.8	10.8	183.8	183.8	177.7	154.4	131.2	108.0
7500	72	216.7	9.6	158.0	135.9	113.8	91.7	-	-	208.9	11.0	161.7	137.2	112.7	88.2	-	-
	67	208.1	9.7	208.1	173.0	150.9	128.8	106.6	-	199.1	10.9	199.1	175.2	150.7	126.2	101.7	-
	62	191.9	9.6	191.9	191.9	177.5	155.4	133.3	111.2	183.7	10.8	183.7	183.7	176.5	152.0	127.4	102.9
	57	197.5	9.5	197.5	197.5	196.3	174.2	152.1	130.0	186.9	10.8	186.9	186.9	186.3	161.8	137.3	112.8
				95°F						105°F							
3750	77	192.2	12.4	83.9	67.1	50.4	-	-	-	183.7	13.9	77.7	64.2	47.6	-	-	-
	72	182.2	12.2	110.9	94.1	77.4	60.6	-	-	171.7	13.8	106.6	90.0	73.4	56.8	-	-
	67	172.2	12.0	137.9	121.1	104.3	87.6	70.8	-	159.6	13.6	135.5	115.9	99.3	82.7	66.1	-
	62	159.0	11.9	159.0	147.9	124.0	107.2	90.5	73.7	149.7	13.5	149.7	140.5	116.6	100.0	83.5	66.9
4500	77	196.6	12.5	93.3	74.3	55.3	-	-	-	188.1	14.0	90.2	71.2	52.3	-	-	-
	72	186.3	12.3	122.9	104.0	85.0	66.0	-	-	175.8	13.8	118.6	99.6	80.6	61.6	-	-
	67	176.1	12.1	152.6	133.6	114.7	95.7	76.7	-	163.4	13.6	147.0	128.0	109.0	90.0	71.0	-
	62	162.6	11.9	162.6	155.2	136.3	117.3	98.3	79.4	153.3	13.5	153.3	147.1	128.1	109.1	90.1	71.1
57	163.4	11.9	163.4	155.2	136.2	117.2	98.3	79.3	153.3	13.5	153.3	147.1	128.1	109.1	90.1	71.1	
5250	77	201.0	12.5	102.6	81.5	60.3	-	-	-	192.5	14.0	102.8	78.3	56.9	-	-	-
	72	190.5	12.3	134.9	113.8	92.6	71.5	-	-	179.8	13.9	130.6	109.2	87.9	66.5	-	-
	67	180.1	12.1	167.3	146.1	125.0	103.8	82.7	-	167.2	13.7	158.5	140.2	118.8	97.4	76.0	-
	62	166.3	12.0	166.3	162.6	148.5	127.4	106.2	85.1	156.8	13.6	156.8	153.7	139.6	118.2	96.8	75.4
57	167.1	12.0	167.1	163.0	148.5	127.3	106.2	85.0	156.8	13.6	156.8	153.7	139.5	118.1	96.7	75.4	
6000	77	205.4	12.6	112.0	88.6	65.3	-	-	-	196.8	14.1	115.3	85.4	61.6	-	-	-
	72	194.7	12.4	147.0	123.6	100.3	76.9	-	-	183.9	13.9	142.6	118.9	95.1	71.3	-	-
	67	184.0	12.2	181.9	158.6	135.3	111.9	88.6	-	171.0	13.7	170.0	152.3	128.5	104.7	81.0	-
	62	169.9	12.0	169.9	169.9	160.8	137.4	114.1	90.8	160.4	13.6	160.4	160.4	151.0	127.2	103.4	79.7
57	170.8	12.0	170.8	170.8	160.7	137.4	114.0	90.7	160.4	13.6	160.4	160.4	151.0	127.2	103.4	79.6	
6750	72	197.9	12.4	156.2	131.1	105.9	80.8	-	-	187.5	13.9	152.4	126.7	101.0	75.2	-	-
	67	187.0	12.2	186.0	168.0	142.9	117.8	92.6	-	174.3	13.7	173.8	161.8	136.5	110.8	85.1	-
	62	172.7	12.0	172.7	172.7	168.1	143.0	117.9	92.7	163.5	13.6	163.5	163.5	158.8	133.1	107.4	81.6
	57	173.6	12.1	173.6	173.6	168.5	143.4	118.3	93.1	163.5	13.6	163.5	163.5	158.8	133.1	107.3	81.6
7500	72	201.1	12.4	165.4	138.5	111.6	84.7	-	-	191.0	13.9	162.2	134.5	106.8	79.2	-	-
	67	190.0	12.2	190.0	177.4	150.5	123.6	96.7	-	177.6	13.7	177.6	171.3	144.5	116.8	89.2	-
	62	175.5	12.1	175.5	175.5	175.5	148.6	121.6	94.7	166.6	13.6	166.6	166.6	166.6	138.9	111.3	83.6
	57	176.3	12.1	176.3	176.3	176.3	149.4	122.5	95.6	166.6	13.7	166.6	166.6	166.6	138.9	111.3	83.6

ZT180 (15 ton) (continued)

Air on evaporator coil		Temperature of air on condenser coil															
		Total capacity ¹ (MBh)	Total input (kW) ²	Sensible capacity (MBh)						Total capacity ¹ (MBh)	Total input (kW) ²	Sensible capacity (MBh)					
				Return dry bulb (°F)								Return dry bulb (°F)					
				90	85	80	75	70	65			90	85	80	75	70	65
		115°F								125°F							
3750	77	175.3	15.5	71.5	61.2	44.8	-	-	-	166.9	17.0	64.7	58.2	42.0	-	-	-
	72	161.2	15.3	102.3	85.9	69.5	53.1	-	-	150.7	16.9	98.0	81.8	65.6	49.3	-	-
	67	147.1	15.2	133.2	110.6	94.2	77.8	61.4	-	134.6	16.7	130.8	105.4	89.1	72.9	56.6	-
	62	140.4	15.0	140.4	133.1	109.3	92.9	76.4	60.0	131.1	16.6	131.1	125.7	101.9	85.7	69.4	53.2
4500	77	179.6	15.5	87.2	68.2	49.2	-	-	-	171.2	17.0	84.2	65.1	46.1	-	-	-
	72	165.2	15.3	114.3	95.3	76.3	57.3	-	-	154.6	16.9	110.0	91.0	71.9	52.9	-	-
	67	150.7	15.2	141.4	122.4	103.4	84.4	65.3	-	138.0	16.8	135.9	116.8	97.8	78.7	59.6	-
	62	143.9	15.1	143.9	139.0	119.9	100.9	81.9	62.9	134.5	16.7	134.5	130.8	111.8	92.7	73.7	54.6
57	143.1	15.1	143.1	139.0	119.9	100.9	81.9	62.8	132.9	16.7	132.9	130.8	111.8	92.7	73.7	54.6	
5250	77	184.0	15.5	103.0	75.2	53.5	-	-	-	175.4	17.0	103.7	72.0	50.1	-	-	-
	72	169.2	15.4	126.3	104.7	83.1	61.4	-	-	158.5	16.9	122.0	100.2	78.3	56.4	-	-
	67	154.3	15.2	149.7	134.2	112.6	91.0	69.3	-	141.5	16.8	140.9	128.3	106.4	84.5	62.7	-
	62	147.3	15.1	147.3	144.9	130.6	109.0	87.3	65.7	137.9	16.7	137.9	136.0	121.7	99.8	77.9	56.0
57	146.5	15.2	146.5	144.5	130.6	109.0	87.3	65.7	136.2	16.8	136.2	135.2	121.7	99.8	77.9	56.0	
6000	77	188.3	15.6	118.7	82.2	57.9	-	-	-	179.7	17.1	123.1	78.9	54.2	-	-	-
	72	173.1	15.4	138.3	114.1	89.9	65.6	-	-	162.3	17.0	134.0	109.3	84.6	59.9	-	-
	67	158.0	15.3	158.0	146.0	121.8	97.6	73.3	-	144.9	16.8	144.9	139.8	115.1	90.4	65.7	-
	62	150.8	15.2	150.8	150.8	141.3	117.0	92.8	68.6	141.2	16.7	141.2	141.2	131.6	106.9	82.2	57.5
57	150.0	15.2	150.0	150.0	141.3	117.0	92.8	68.5	139.6	16.8	139.6	139.6	131.6	106.9	82.2	57.5	
6750	72	177.1	15.4	148.6	122.3	96.0	69.7	-	-	166.7	17.0	144.8	117.9	91.0	64.1	-	-
	67	161.6	15.3	161.6	155.6	130.1	103.8	77.5	-	148.8	16.8	148.8	148.8	123.7	96.8	69.9	-
	62	154.2	15.2	154.2	154.2	149.5	123.2	96.9	70.5	145.0	16.7	145.0	145.0	140.2	113.3	86.3	59.4
	57	153.4	15.2	153.4	153.4	149.0	122.7	96.4	70.1	143.3	16.8	143.3	143.3	139.3	112.4	85.5	58.6
7500	72	181.0	15.5	158.9	130.5	102.1	73.7	-	-	171.0	17.0	155.6	126.5	97.4	68.3	-	-
	67	165.2	15.3	165.2	165.2	138.4	110.0	81.7	-	152.7	16.9	152.7	152.7	132.4	103.3	74.1	-
	62	157.7	15.2	157.7	157.7	157.7	129.3	100.9	72.5	148.8	16.7	148.8	148.8	148.8	119.6	90.5	61.4
	57	156.8	15.2	156.8	156.8	156.8	128.4	100.0	71.7	147.0	16.8	147.0	147.0	147.0	117.9	88.8	59.7

1. These capacities are gross ratings. For net capacity, deduct air blower motor, MBh = 3.415 x kW. Refer to the appropriate Blower Performance Table for the kW of the supply air blower motor.
2. These ratings include the condenser fan motors (total 1 kW) and the compressor motors but not the supply air blower motor.

ZT180 (15 ton) optional reheat mode

Air on evaporator coil		Temperature of air on condenser coil																	
CFM	WB (°F)	Total capacity ¹ (MBh)	Total input (kW) ²	Sensible capacity (MBh)								Total capacity ¹ (MBh)	Total input (kW) ²	Sensible capacity (MBh)					
				Return dry bulb (°F)										Return dry bulb (°F)					
				90	85	80	75	70	65	90	85			80	75	70	65		
				35°F								45°F							
3750	72	61.4	3.6	25.6	21.0	16.4	11.8	-	-	69.4	4.5	19.9	15.7	11.5	7.4	-	-		
	67	67.7	3.5	47.2	42.6	38.0	33.4	28.8	-	69.4	4.3	39.0	34.8	30.7	26.5	22.3	-		
	62	69.1	2.9	66.2	59.7	56.7	52.1	47.5	42.9	67.7	4.2	57.4	50.4	45.7	41.6	37.4	33.2		
4500	72	62.5	3.9	26.5	22.1	17.8	13.4	-	-	70.1	4.5	22.4	17.8	13.2	8.6	-	-		
	67	68.8	3.7	48.7	44.3	39.9	35.6	31.2	-	70.1	4.3	44.3	39.7	35.1	30.5	25.9	-		
	62	70.3	3.1	68.4	64.0	59.6	55.2	50.9	46.5	68.5	4.2	61.5	56.9	52.3	47.7	43.1	38.5		
	57	70.0	3.2	69.9	65.5	61.2	56.8	52.4	48.1	69.4	4.2	62.9	58.3	53.7	49.1	44.5	39.9		
5250	72	63.6	4.1	27.4	23.2	19.1	15.0	-	-	70.9	4.5	25.0	19.9	14.9	9.8	-	-		
	67	70.0	3.9	50.1	46.0	41.9	37.7	33.6	-	70.9	4.3	49.6	44.5	39.5	34.4	29.4	-		
	62	71.4	3.3	70.5	68.3	62.5	58.4	54.2	50.1	69.2	4.2	65.7	63.4	58.9	53.9	48.8	43.8		
	57	71.2	3.4	71.2	69.0	64.1	60.0	55.9	51.7	70.1	4.2	66.9	64.6	60.5	55.4	50.4	45.3		
6000	72	64.8	4.3	28.3	24.4	20.5	16.6	-	-	71.6	4.5	27.5	22.0	16.5	11.0	-	-		
	67	71.2	4.1	51.6	47.7	43.8	39.9	36.0	-	71.6	4.3	54.9	49.4	43.9	38.4	32.9	-		
	62	72.6	3.5	72.6	72.6	65.4	61.5	57.6	53.7	69.9	4.2	69.9	69.9	65.5	60.0	54.5	49.0		
	57	72.4	3.6	72.4	72.4	67.1	63.2	59.3	55.4	70.9	4.2	70.9	70.9	67.3	61.8	56.3	50.8		
6750	72	66.4	4.5	35.3	29.1	23.0	16.8	-	-	72.9	4.6	32.6	25.6	18.6	11.6	-	-		
	67	72.8	4.3	61.4	55.3	49.1	42.9	36.7	-	73.0	4.4	63.3	56.4	49.4	42.4	35.4	-		
	62	74.3	3.7	74.3	74.3	70.7	64.5	58.3	52.1	71.2	4.3	71.2	71.2	69.0	62.0	55.0	48.0		
	57	74.0	3.8	74.0	74.0	71.4	65.2	59.1	52.9	72.2	4.3	72.2	72.2	70.4	63.4	56.4	49.4		
7500	72	67.9	4.7	42.4	33.9	25.5	17.0	-	-	74.3	4.7	37.6	29.1	20.7	12.2	-	-		
	67	74.5	4.5	71.3	62.8	54.4	45.9	37.5	-	74.3	4.5	71.8	63.3	54.8	46.3	37.8	-		
	62	75.9	3.9	75.9	75.9	75.9	67.5	59.0	50.5	72.5	4.4	72.5	72.5	72.5	64.0	55.5	47.1		
	57	75.7	4.0	75.7	75.7	75.7	67.3	58.8	50.3	73.5	4.4	73.5	73.5	73.5	65.0	56.5	48.0		
				55°F								65°F							
3750	72	77.4	5.3	14.1	10.4	6.7	3.0	-	-	74.5	5.6	10.8	7.3	3.8	0.4	-	-		
	67	71.1	5.1	30.8	27.0	23.3	19.6	15.9	-	67.5	5.4	28.1	24.6	21.1	17.7	14.2	-		
	62	66.4	5.5	48.5	41.2	34.7	31.0	27.3	23.6	63.2	5.6	44.7	37.6	31.3	27.9	24.4	21.0		
4500	72	77.8	5.1	18.4	13.5	8.7	3.8	-	-	75.1	5.4	14.4	9.7	5.0	-	-	-		
	67	71.4	4.9	39.9	35.1	30.2	25.4	20.5	-	68.1	5.3	37.7	33.0	28.3	23.6	18.9	-		
	62	66.7	5.3	54.7	49.9	45.0	40.2	35.4	30.5	63.7	5.5	51.4	46.7	42.0	37.3	32.6	27.9		
	57	68.8	5.2	56.0	51.1	46.3	41.4	36.6	31.7	65.5	5.4	52.1	47.4	42.7	38.0	33.3	28.6		
5250	72	78.1	4.9	22.6	16.6	10.6	4.7	-	-	75.7	5.3	18.1	12.1	6.2	-	-	-		
	67	71.8	4.7	49.1	43.1	37.1	31.2	25.2	-	68.6	5.1	47.4	41.4	35.5	29.6	23.6	-		
	62	67.0	5.0	61.0	58.6	55.3	49.4	43.4	37.4	64.2	5.3	58.0	55.7	52.6	46.7	40.7	34.8		
	57	69.1	5.0	62.7	60.2	56.8	50.9	44.9	38.9	66.0	5.3	59.3	57.0	53.5	47.6	41.6	35.7		
6000	72	78.4	4.7	26.8	19.7	12.6	5.5	-	-	76.4	5.2	21.7	14.6	7.4	-	-	-		
	67	72.1	4.5	58.2	51.1	44.0	36.9	29.8	-	69.2	5.0	57.0	49.8	42.7	35.5	28.3	-		
	62	67.2	4.8	67.2	67.2	65.6	58.5	51.4	44.3	64.7	5.2	64.7	64.7	63.2	56.1	48.9	41.7		
	57	69.4	4.7	69.4	69.4	67.4	60.3	53.2	46.1	66.6	5.1	66.6	66.6	64.3	57.1	50.0	42.8		
6750	72	79.5	4.7	29.8	22.0	14.2	6.4	-	-	77.4	5.1	24.4	16.4	8.4	-	-	-		
	67	73.1	4.5	65.2	57.4	49.6	41.8	34.0	-	70.1	5.0	63.6	56.6	48.6	40.6	32.6	-		
	62	68.2	4.8	68.2	68.2	67.4	59.6	51.8	44.0	65.6	5.2	65.6	65.6	64.9	56.9	48.9	40.9		
	57	70.3	4.7	70.3	70.3	69.3	61.5	53.7	45.9	67.5	5.1	67.5	67.5	66.4	58.4	50.4	42.4		
7500	72	80.6	4.7	32.9	24.4	15.8	7.3	-	-	78.4	5.1	27.0	18.2	9.3	-	-	-		
	67	74.1	4.5	72.3	63.8	55.2	46.7	38.2	-	71.1	5.0	70.2	63.4	54.5	45.7	36.9	-		
	62	69.1	4.8	69.1	69.1	69.1	60.6	52.1	43.6	66.5	5.1	66.5	66.5	66.5	57.7	48.8	40.0		
	57	71.3	4.7	71.3	71.3	71.3	62.8	54.2	45.7	68.4	5.1	68.4	68.4	68.4	59.6	50.7	41.9		

ZT180 (15 ton) optional reheat mode (continued)

Air on evaporator coil		Temperature of air on condenser coil															
CFM	WB (°F)	Total capacity ¹ (MBh)	Total input (kW) ²	Sensible capacity (MBh)						Total capacity ¹ (MBh)	Total input (kW) ²	Sensible capacity (MBh)					
				Return dry bulb (°F)								Return dry bulb (°F)					
				90	85	80	75	70	65			90	85	80	75	70	65
				75°F						85°F							
3750	72	71.6	5.9	7.4	4.2	1.0	-2.2	-	-	68.7	6.2	4.0	1.1	-1.9	-4.8	-	-
	67	63.9	5.8	25.4	22.2	19.0	15.8	12.6	-	60.3	6.1	22.7	19.7	16.8	13.8	10.9	-
	62	60.0	5.8	40.9	34.1	27.9	24.7	21.5	18.3	56.8	5.9	37.1	30.5	24.5	21.6	18.6	15.7
4500	72	72.5	5.8	10.5	5.9	-	-	-	-	69.8	6.2	6.5	2.1	-	-	-	-
	67	64.7	5.7	35.5	31.0	26.4	21.9	17.3	-	61.4	6.1	33.3	28.9	24.5	20.1	15.7	-
	62	60.7	5.7	48.0	43.4	38.9	34.3	29.8	25.2	57.8	5.9	44.6	40.2	35.8	31.4	27.0	22.6
	57	62.2	5.7	48.2	43.7	39.1	34.6	30.0	25.5	59.0	5.9	44.4	40.0	35.6	31.2	26.8	22.4
5250	72	73.4	5.7	13.6	7.7	-	-	-	-	71.0	6.2	9.1	3.2	-	-	-	-
	67	65.5	5.6	45.7	39.8	33.9	28.0	22.1	-	62.4	6.1	44.0	38.1	32.2	26.4	20.5	-
	62	61.5	5.6	55.1	52.8	49.9	44.0	38.1	32.2	58.7	5.9	52.2	50.0	47.1	41.3	35.4	29.5
	57	63.0	5.6	56.0	53.7	50.2	44.3	38.4	32.5	60.0	5.9	52.7	50.5	46.8	41.0	35.1	29.2
6000	72	74.3	5.7	16.7	9.4	-	-	-	-	72.2	6.2	11.6	4.2	-	-	-	-
	67	66.3	5.5	55.8	48.6	41.3	34.1	26.8	-	63.4	6.1	54.6	47.3	40.0	32.6	25.3	-
	62	62.2	5.5	62.2	62.2	60.8	53.6	46.3	39.1	59.7	5.9	59.7	59.7	58.5	51.1	43.8	36.5
	57	63.8	5.5	63.8	63.8	61.2	54.0	46.7	39.5	61.0	5.9	61.0	61.0	58.1	50.8	43.5	36.1
6750	72	75.3	5.6	18.9	10.7	-	-	-	-	73.2	6.1	13.4	5.0	-	-	-	-
	67	67.2	5.5	62.0	55.8	47.6	39.4	31.2	-	64.3	6.0	60.3	54.9	46.5	38.1	29.7	-
	62	63.1	5.5	63.1	63.1	62.4	54.2	46.0	37.8	60.5	5.8	60.5	60.5	59.9	51.5	43.1	34.7
	57	64.6	5.5	64.6	64.6	63.4	55.2	47.0	38.8	61.8	5.8	61.8	61.8	60.4	52.0	43.6	35.2
7500	72	76.3	5.6	21.1	11.9	-	-	-	-	74.1	6.1	15.2	5.7	-	-	-	-
	67	68.1	5.5	68.1	63.0	53.8	44.7	35.5	-	65.2	6.0	65.2	62.6	53.1	43.6	34.2	-
	62	63.9	5.5	63.9	63.9	63.9	54.8	45.6	36.5	61.3	5.8	61.3	61.3	61.3	51.9	42.4	32.9
	57	65.5	5.5	65.5	65.5	65.5	56.4	47.2	38.1	62.6	5.8	62.6	62.6	62.6	53.2	43.7	34.2

1. These capacities are gross ratings. For net capacity, deduct air blower motor, MBh = 3.415 x kW. Refer to the appropriate Blower Performance Table for the kW of the supply air blower motor.
2. These ratings include the condenser fan motors (total 1 kW) and the compressor motors but not the supply air blower motor.

- No sensible cooling capacity

ZT210 (17.5 ton)

Air on evaporator coil		Temperature of air on condenser coil															
CFM	WB (°F)	Total capacity ¹ (MBh)	Total input (kW) ²	Sensible capacity (MBh)						Total capacity ¹ (MBh)	Total input (kW) ²	Sensible capacity (MBh)					
				Return dry bulb (°F)								Return dry bulb (°F)					
				90	85	80	75	70	65			90	85	80	75	70	65
		75°F								85°F							
4375	77	248.9	11.4	112.4	94.0	75.7	-	-	-	237.3	12.8	105.5	87.2	68.9	-	-	-
	72	232.0	11.2	142.9	124.6	106.2	87.9	-	-	220.6	12.6	135.2	116.9	98.5	80.2	-	-
	67	215.2	11.0	173.5	155.1	136.8	118.4	100.1	-	203.8	12.5	164.8	146.5	128.2	109.9	91.6	-
	62	196.9	10.9	196.9	170.6	154.8	136.5	118.1	99.8	185.6	12.3	185.6	169.0	148.2	129.9	111.6	93.3
5250	77	257.7	11.5	122.5	101.7	81.0	-	-	-	245.3	12.9	115.9	95.2	74.4	-	-	-
	72	240.2	11.3	155.1	134.4	113.7	93.0	-	-	228.0	12.8	147.9	127.2	106.4	85.7	-	-
	67	222.7	11.1	187.8	167.1	146.3	125.6	104.9	-	210.7	12.6	179.9	159.2	138.4	117.7	96.9	-
	62	203.8	11.0	203.8	186.3	165.6	144.9	124.1	103.4	191.8	12.4	191.8	180.8	160.0	139.3	118.6	97.8
	57	206.2	10.9	206.2	200.8	180.1	159.4	138.6	117.9	193.6	12.4	193.6	190.6	169.8	149.1	128.3	107.6
6125	77	266.4	11.7	132.5	109.5	86.4	-	-	-	253.3	13.1	126.3	103.1	79.9	-	-	-
	72	248.4	11.4	167.3	144.2	121.1	98.0	-	-	235.4	12.9	160.7	137.5	114.3	91.1	-	-
	67	230.3	11.2	202.1	179.0	155.9	132.8	109.7	-	217.6	12.7	195.0	171.8	148.7	125.5	102.3	-
	62	210.7	11.1	210.7	202.0	176.3	153.2	130.1	107.1	198.1	12.5	198.1	192.6	171.9	148.7	125.5	102.3
	57	213.2	11.1	213.2	210.5	191.9	168.8	145.7	122.6	200.0	12.5	200.0	198.4	182.4	159.2	136.0	112.8
7000	77	275.2	11.8	142.6	117.2	91.7	-	-	-	261.3	13.2	136.7	111.1	85.4	-	-	-
	72	256.5	11.6	179.5	154.1	128.6	103.1	-	-	242.9	13.0	173.4	147.8	122.2	96.6	-	-
	67	237.9	11.3	216.4	190.9	165.5	140.0	114.5	-	224.4	12.8	210.2	184.5	158.9	133.3	107.7	-
	62	217.7	11.2	217.7	217.7	187.1	161.6	136.2	110.7	204.4	12.6	204.4	204.4	183.7	158.1	132.5	106.9
	57	220.2	11.2	220.2	220.2	203.6	178.2	152.7	127.2	206.3	12.6	206.3	206.3	194.9	169.3	143.7	118.1
7875	72	260.8	11.6	189.8	162.7	135.6	108.5	-	-	246.3	13.0	184.4	157.1	129.8	102.4	-	-
	67	241.8	11.4	231.1	201.6	174.5	147.4	120.3	-	227.6	12.8	220.5	196.1	168.8	141.5	114.1	-
	62	221.3	11.2	221.3	221.3	202.4	175.3	148.2	121.0	207.3	12.6	207.3	207.3	195.1	167.8	140.5	113.2
	57	223.8	11.2	223.8	223.8	215.5	188.4	161.3	134.2	209.2	12.6	209.2	209.2	203.5	176.2	148.9	121.6
8750	72	265.0	11.6	200.1	171.4	142.7	113.9	-	-	249.8	13.0	195.4	166.4	137.3	108.3	-	-
	67	245.8	11.4	245.8	212.3	183.5	154.8	126.0	-	230.8	12.8	230.8	207.7	178.6	149.6	120.6	-
	62	224.9	11.3	224.9	224.9	217.6	188.9	160.2	131.4	210.2	12.6	210.2	210.2	206.5	177.5	148.5	119.5
	57	227.4	11.2	227.4	227.4	227.4	198.7	170.0	141.2	212.1	12.6	212.1	212.1	212.1	183.1	154.1	125.1
		95°F								105°F							
4375	77	225.7	14.2	98.7	80.4	62.1	-	-	-	211.6	15.9	90.1	74.8	56.5	-	-	-
	72	209.1	14.1	127.4	109.1	90.9	72.6	-	-	196.4	15.8	121.8	103.5	85.2	66.9	-	-
	67	192.5	13.9	156.1	137.8	119.6	101.3	83.1	-	181.2	15.6	153.5	132.2	113.9	95.6	77.3	-
	62	174.3	13.7	174.3	167.4	141.6	123.3	105.1	86.8	168.0	15.4	168.0	161.1	134.2	115.9	97.6	79.3
5250	77	233.0	14.3	109.4	88.6	67.8	-	-	-	217.8	16.1	103.8	82.9	62.0	-	-	-
	72	215.8	14.2	140.7	119.9	99.2	78.4	-	-	202.1	15.9	135.3	114.4	93.5	72.6	-	-
	67	198.6	14.0	172.0	151.3	130.5	109.7	89.0	-	186.5	15.8	166.8	145.9	125.0	104.1	83.2	-
	62	179.9	13.8	179.9	175.3	154.5	133.8	113.0	92.2	172.8	15.6	172.8	168.2	147.3	126.4	105.5	84.6
	57	181.1	13.8	181.1	180.3	159.5	138.8	118.0	97.2	173.8	15.6	173.8	170.5	149.6	128.7	107.9	87.0
6125	77	240.2	14.5	120.1	96.8	73.5	-	-	-	223.9	16.2	117.6	91.0	67.5	-	-	-
	72	222.5	14.3	154.0	130.7	107.5	84.2	-	-	207.8	16.1	148.8	125.3	101.8	78.4	-	-
	67	204.8	14.2	188.0	164.7	141.4	118.2	94.9	-	191.7	16.0	180.1	159.7	136.2	112.7	89.2	-
	62	185.5	13.9	185.5	183.2	167.5	144.2	120.9	97.6	177.6	15.7	177.6	175.4	160.4	137.0	113.5	90.0
	57	186.8	13.9	186.8	186.4	172.9	149.6	126.3	103.1	178.7	15.7	178.7	177.0	162.9	139.5	116.0	92.5
7000	77	247.5	14.6	130.7	105.0	79.2	-	-	-	230.0	16.4	131.3	99.1	73.0	-	-	-
	72	229.2	14.5	167.3	141.5	115.8	90.0	-	-	213.5	16.3	162.3	136.2	110.2	84.1	-	-
	67	211.0	14.3	203.9	178.1	152.4	126.6	100.8	-	196.9	16.1	193.4	173.4	147.3	121.2	95.1	-
	62	191.1	14.0	191.1	191.1	180.4	154.6	128.8	103.0	182.5	15.9	182.5	182.5	173.6	147.5	121.4	95.3
	57	192.4	14.1	192.4	192.4	186.3	160.5	134.7	108.9	183.5	15.9	183.5	183.5	176.3	150.2	124.1	98.0
7875	72	231.9	14.4	179.0	151.4	123.9	96.4	-	-	215.6	16.2	173.2	145.4	117.7	90.0	-	-
	67	213.4	14.3	209.9	190.6	163.1	135.5	108.0	-	198.9	16.1	197.1	183.9	157.4	129.6	101.9	-
	62	193.3	14.0	193.3	193.3	187.9	160.4	132.9	105.3	184.3	15.9	184.3	184.3	179.8	152.1	124.3	96.6
	57	194.6	14.0	194.6	194.6	191.5	164.0	136.5	108.9	185.3	15.9	185.3	185.3	181.7	154.0	126.2	98.5
8750	72	234.5	14.4	190.6	161.3	132.0	102.7	-	-	217.7	16.2	184.0	154.6	125.2	95.8	-	-
	67	215.8	14.3	215.8	203.0	173.8	144.5	115.2	-	200.8	16.1	200.8	194.4	167.4	138.0	108.6	-
	62	195.5	14.0	195.5	195.5	195.5	166.2	136.9	107.6	186.1	15.8	186.1	186.1	186.1	156.7	127.3	97.9
	57	196.8	14.0	196.8	196.8	196.8	167.5	138.2	108.9	187.1	15.8	187.1	187.1	187.1	157.7	128.3	98.9

ZT210 (17.5 ton) (continued)

Air on evaporator coil		Temperature of air on condenser coil															
		Total capacity ¹ (MBh)	Total input (kW) ²	Sensible capacity (MBh)						Total capacity ¹ (MBh)	Total input (kW) ²	Sensible capacity (MBh)					
				Return dry bulb (°F)								Return dry bulb (°F)					
				90	85	80	75	70	65			90	85	80	75	70	65
		115°F								125°F							
4375	77	197.6	17.6	81.5	69.2	50.9	-	-	-	183.5	19.3	71.1	63.6	45.3	-	-	-
	72	183.8	17.5	116.2	97.9	79.5	61.2	-	-	171.2	19.2	110.6	92.3	73.9	55.5	-	-
	67	170.0	17.4	151.0	126.6	108.2	89.9	71.5	-	158.8	19.1	148.4	120.9	102.5	84.2	65.8	-
	62	161.7	17.2	161.7	154.8	126.9	108.5	90.2	71.8	155.4	18.9	155.4	148.5	119.5	101.1	82.7	64.4
5250	77	202.6	17.8	98.3	77.2	56.2	-	-	-	187.4	19.5	92.7	71.6	50.4	-	-	-
	72	188.4	17.7	129.9	108.9	87.9	66.9	-	-	174.7	19.4	124.5	103.4	82.2	61.1	-	-
	67	174.3	17.6	161.6	140.6	119.6	98.5	77.5	-	162.1	19.3	156.4	135.2	114.1	92.9	71.8	-
	62	165.7	17.4	165.7	161.2	140.1	119.1	98.1	77.1	158.7	19.1	158.7	154.1	133.0	111.8	90.7	69.5
57	166.5	17.4	166.5	160.8	139.7	118.7	97.7	76.7	159.2	19.1	159.2	151.0	129.8	108.7	87.5	66.4	-
6125	77	207.5	18.0	115.1	85.3	61.6	-	-	-	191.2	19.7	114.3	79.5	55.6	-	-	-
	72	193.0	17.9	143.6	119.9	96.2	72.5	-	-	178.3	19.6	138.4	114.5	90.6	66.7	-	-
	67	178.6	17.7	172.2	154.6	130.9	107.2	83.5	-	165.4	19.5	164.3	149.6	125.6	101.7	77.8	-
	62	169.8	17.5	169.8	167.5	153.4	129.7	106.0	82.3	162.0	19.4	162.0	159.7	146.4	122.5	98.6	74.7
57	170.6	17.5	170.6	167.7	153.0	129.3	105.6	81.9	162.5	19.3	162.5	158.4	143.1	119.1	95.2	71.3	-
7000	77	212.5	18.2	131.9	93.3	66.9	-	-	-	195.0	20.0	136.0	87.4	60.7	-	-	-
	72	197.7	18.1	157.3	131.0	104.6	78.2	-	-	181.9	19.9	152.3	125.7	99.0	72.3	-	-
	67	182.8	17.9	182.8	168.6	142.2	115.9	89.5	-	168.7	19.7	168.7	163.9	137.2	110.5	83.8	-
	62	173.9	17.7	173.9	173.9	166.7	140.4	114.0	87.6	165.3	19.6	165.3	165.3	159.9	133.2	106.5	79.8
57	174.6	17.7	174.6	174.6	166.3	139.9	113.5	87.1	165.8	19.5	165.8	165.8	156.3	129.6	102.9	76.2	-
7875	72	199.3	18.0	167.4	139.4	111.5	83.5	-	-	183.0	19.8	161.6	133.5	105.3	77.1	-	-
	67	184.3	17.9	184.3	177.2	151.7	123.7	95.8	-	169.8	19.7	169.8	169.8	146.0	117.8	89.7	-
	62	175.3	17.7	175.3	175.3	171.7	143.8	115.8	87.9	166.3	19.5	166.3	166.3	163.6	135.5	107.3	79.1
	57	176.1	17.7	176.1	176.1	171.9	143.9	116.0	88.0	166.8	19.5	166.8	166.8	162.0	133.9	105.7	77.6
8750	72	200.9	18.0	177.5	147.9	118.4	88.9	-	-	184.1	19.7	170.9	141.3	111.6	82.0	-	-
	67	185.8	17.8	185.8	185.8	161.1	131.6	102.1	-	170.8	19.6	170.8	170.8	154.8	125.1	95.5	-
	62	176.7	17.6	176.7	176.7	176.7	147.2	117.7	88.2	167.3	19.4	167.3	167.3	167.3	137.7	108.1	78.4
	57	177.5	17.6	177.5	177.5	177.5	148.0	118.5	88.9	167.8	19.4	167.8	167.8	167.8	138.2	108.6	78.9

1. These capacities are gross ratings. For net capacity, deduct air blower motor, MBh = 3.415 x kW. Refer to the appropriate Blower Performance Table for the kW of the supply air blower motor.
2. These ratings include the condenser fan motors (total 1 kW) and the compressor motors but not the supply air blower motor.

ZT210 (17.5 ton) optional reheat mode

Air on evaporator coil		Temperature of air on condenser coil															
CFM	WB (°F)	Total capacity ¹ (MBh)	Total input (kW) ²	Sensible capacity (MBh)						Total capacity ¹ (MBh)	Total input (kW) ²	Sensible capacity (MBh)					
				Return dry bulb (°F)								Return dry bulb (°F)					
				90	85	80	75	70	65			90	85	80	75	70	65
				35°F						45°F							
4375	72	87.1	4.7	39.1	31.9	24.7	17.5	-	-	87.5	5.3	29.6	23.6	17.7	11.8	-	-
	67	90.9	4.1	68.7	61.5	54.3	47.1	40.0	-	84.8	5.1	54.0	48.1	42.2	36.3	30.4	-
	62	91.1	3.9	91.1	86.0	75.6	68.5	61.3	54.1	81.7	5.0	78.8	69.2	59.6	53.7	47.8	41.9
5250	72	85.3	4.8	40.2	33.3	26.4	19.5	-	-	87.7	5.3	32.8	26.4	20.0	13.6	-	-
	67	89.4	4.2	70.9	64.0	57.1	50.3	43.4	-	85.0	5.1	60.4	54.0	47.6	41.2	34.8	-
	62	89.6	4.0	89.6	86.2	79.4	72.5	65.6	58.7	82.0	5.0	80.0	73.6	67.2	60.8	54.4	48.0
	57	88.8	4.0	88.8	85.5	78.6	71.7	64.8	58.0	81.3	5.0	79.5	73.1	66.7	60.3	53.9	47.5
6125	72	83.5	4.9	41.3	34.7	28.1	21.5	-	-	87.9	5.3	36.0	29.1	22.2	15.4	-	-
	67	87.8	4.3	73.1	66.6	60.0	53.4	46.8	-	85.2	5.1	66.8	59.9	53.0	46.1	39.2	-
	62	88.2	4.1	88.2	86.5	83.1	76.5	69.9	63.3	82.2	5.0	81.2	78.0	74.8	67.9	61.0	54.1
	57	87.3	4.1	87.3	85.7	82.3	75.7	69.1	62.5	81.6	5.0	80.6	77.4	74.2	67.3	60.5	53.6
7000	72	81.7	5.0	42.4	36.1	29.8	23.5	-	-	88.2	5.3	39.3	31.9	24.5	17.1	-	-
	67	86.2	4.5	75.4	69.1	62.8	56.5	50.2	-	85.5	5.1	73.1	65.8	58.4	51.0	43.6	-
	62	86.8	4.2	86.8	86.8	86.8	80.5	74.2	68.0	82.4	5.0	82.4	82.4	82.4	75.0	67.6	60.2
	57	85.9	4.2	85.9	85.9	85.9	79.6	73.4	67.1	81.8	5.0	81.8	81.8	81.8	74.4	67.0	59.6
7875	72	79.7	5.1	41.5	35.5	29.5	23.5	-	-	86.8	5.2	40.4	32.6	24.9	17.1	-	-
	67	84.2	4.5	73.6	67.6	61.6	55.6	49.5	-	84.2	5.1	74.7	67.0	59.2	51.5	43.8	-
	62	84.8	4.3	84.8	84.8	84.8	78.8	72.8	66.8	81.2	5.0	81.2	81.2	81.2	73.4	65.7	57.9
	57	84.0	4.3	84.0	84.0	84.0	77.9	71.9	65.9	80.6	5.0	80.6	80.6	80.6	72.8	65.1	57.3
8750	72	77.6	5.1	40.7	34.9	29.2	23.4	-	-	85.5	5.2	41.4	33.3	25.2	17.1	-	-
	67	82.2	4.6	71.9	66.1	60.4	54.6	48.8	-	82.9	5.0	76.3	68.2	60.1	52.0	43.9	-
	62	82.9	4.4	82.9	82.9	82.9	77.1	71.3	65.6	79.9	4.9	79.9	79.9	79.9	71.8	63.7	55.6
	57	82.0	4.4	82.0	82.0	82.0	76.3	70.5	64.7	79.3	4.9	79.3	79.3	79.3	71.2	63.1	55.0
				55°F						65°F							
4375	72	87.9	5.9	20.0	15.4	10.7	6.1	-	-	81.7	6.6	14.6	10.2	5.9	1.5	-	-
	67	78.6	6.1	39.4	34.8	30.1	25.5	20.9	-	73.3	6.6	36.3	31.9	27.6	23.2	18.9	-
	62	72.4	6.1	61.3	52.4	43.6	38.9	34.3	29.6	67.5	6.6	55.7	47.1	38.5	34.2	29.8	25.5
5250	72	90.1	5.8	25.4	19.5	13.6	7.6	-	-	83.8	6.5	18.9	13.2	7.5	-	-	-
	67	80.7	6.0	49.9	44.0	38.1	32.2	26.2	-	75.2	6.5	47.2	41.5	35.8	30.1	24.3	-
	62	74.3	6.0	66.9	60.9	55.0	49.1	43.2	37.3	69.3	6.5	61.3	55.6	49.9	44.2	38.4	32.7
	57	73.9	6.0	66.6	60.7	54.8	48.9	42.9	37.0	69.6	6.5	61.6	55.9	50.2	44.4	38.7	33.0
6125	72	92.4	5.7	30.8	23.6	16.4	9.2	-	-	85.9	6.4	23.2	16.1	9.0	1.9	-	-
	67	82.7	5.9	60.4	53.2	46.0	38.8	31.6	-	77.1	6.4	58.2	51.1	44.0	36.9	29.8	-
	62	76.1	5.9	72.4	69.5	66.5	59.3	52.1	44.9	71.0	6.4	67.0	64.1	61.3	54.2	47.1	40.0
	57	75.8	5.9	72.1	69.2	66.2	59.0	51.8	44.6	71.4	6.4	67.3	64.5	61.6	54.5	47.4	40.3
7000	72	94.6	5.6	36.2	27.7	19.2	10.7	-	-	87.9	6.3	27.5	19.1	10.6	-	-	-
	67	84.7	5.8	70.9	62.4	53.9	45.5	37.0	-	78.9	6.3	69.1	60.6	52.2	43.7	35.2	-
	62	78.0	5.8	78.0	78.0	78.0	69.5	61.0	52.5	72.7	6.3	72.7	72.7	72.7	64.2	55.7	47.3
	57	77.6	5.8	77.6	77.6	77.6	69.1	60.7	52.2	73.1	6.3	73.1	73.1	73.1	64.6	56.1	47.7
7875	72	94.0	5.4	39.2	29.7	20.3	10.8	-	-	87.4	6.2	29.9	20.6	11.2	-	-	-
	67	84.2	5.6	75.8	66.4	56.9	47.5	38.0	-	78.5	6.2	72.8	64.1	54.7	45.4	36.0	-
	62	77.5	5.6	77.5	77.5	77.5	68.0	58.6	49.1	72.3	6.2	72.3	72.3	72.3	62.9	53.5	44.2
	57	77.1	5.6	77.1	77.1	77.1	67.7	58.2	48.8	72.7	6.2	72.7	72.7	72.7	63.3	53.9	44.6
8750	72	93.4	5.2	42.2	31.7	21.3	10.9	-	-	87.0	6.1	32.3	22.0	11.8	-	-	-
	67	83.6	5.4	80.7	70.3	59.9	49.5	39.0	-	78.0	6.1	76.6	67.6	57.3	47.1	36.8	-
	62	77.0	5.4	77.0	77.0	77.0	66.6	56.2	45.7	71.9	6.1	71.9	71.9	71.9	61.6	51.3	41.1
	57	76.6	5.4	76.6	76.6	76.6	66.2	55.8	45.4	72.3	6.1	72.3	72.3	72.3	62.0	51.7	41.5

ZT210 (17.5 ton) optional reheat mode (continued)

Air on evaporator coil		Temperature of air on condenser coil															
CFM	WB (°F)	Total capacity ¹ (MBh)	Total input (kW) ²	Sensible capacity (MBh)						Total capacity ¹ (MBh)	Total input (kW) ²	Sensible capacity (MBh)					
				Return dry bulb (°F)								Return dry bulb (°F)					
				90	85	80	75	70	65			90	85	80	75	70	65
				75°F						85°F							
4375	72	75.6	7.3	9.1	5.1	1.0	-3.1	-	-	69.4	8.0	3.7	-0.1	-3.9	-7.6	-	-
	67	68.0	7.1	33.1	29.1	25.0	21.0	16.9	-	62.7	7.6	30.0	26.2	22.5	18.7	14.9	-
	62	62.7	7.1	50.0	41.7	33.4	29.4	25.3	21.3	57.8	7.5	44.4	36.4	28.4	24.6	20.9	17.1
5250	72	77.4	7.2	12.4	6.9	-	-	-	-	71.1	7.9	5.9	-	-	-	-	-
	67	69.7	7.0	44.5	39.0	33.5	28.0	22.4	-	64.3	7.5	41.8	36.5	31.2	25.8	20.5	-
	62	64.2	7.0	55.8	50.3	44.8	39.2	33.7	28.2	59.2	7.5	50.3	44.9	39.6	34.3	29.0	23.6
	57	65.3	6.9	56.6	51.0	45.5	40.0	34.5	29.0	61.1	7.4	51.5	46.2	40.9	35.6	30.3	24.9
6125	72	79.3	7.1	15.7	8.7	-	-	-	-	72.8	7.8	8.1	-	-	-	-	-
	67	71.4	6.9	55.9	48.9	41.9	34.9	28.0	-	65.8	7.4	53.6	46.8	39.9	33.0	26.1	-
	62	65.8	6.9	61.6	58.8	56.1	49.1	42.1	35.1	60.6	7.4	56.2	53.5	50.8	44.0	37.1	30.2
	57	66.9	6.8	62.5	59.8	57.0	50.0	43.1	36.1	62.5	7.3	57.8	55.1	52.4	45.6	38.7	31.8
7000	72	81.2	7.0	18.9	10.5	-	-	-	-	74.5	7.7	10.3	-	-	-	-	-
	67	73.1	6.8	67.3	58.8	50.4	41.9	33.5	-	67.3	7.3	65.5	57.0	48.6	40.2	31.7	-
	62	67.4	6.8	67.4	67.4	67.4	58.9	50.5	42.0	62.1	7.3	62.1	62.1	62.1	53.6	45.2	36.8
	57	68.5	6.7	68.5	68.5	68.5	60.1	51.6	43.2	64.0	7.2	64.0	64.0	64.0	55.5	47.1	38.7
7875	72	80.8	7.0	20.7	11.4	-	-	-	-	74.2	7.7	11.5	-	-	-	-	-
	67	72.8	6.8	69.9	61.9	52.6	43.3	34.0	-	67.1	7.4	66.9	59.6	50.4	41.2	32.0	-
	62	67.1	6.8	67.1	67.1	67.1	57.8	48.5	39.2	61.8	7.3	61.8	61.8	61.8	52.6	43.4	34.2
	57	68.2	6.7	68.2	68.2	68.2	58.9	49.6	40.4	63.8	7.3	63.8	63.8	63.8	54.6	45.3	36.1
8750	72	80.5	6.9	22.5	12.3	-	-	-	-	74.0	7.8	12.6	-	-	-	-	-
	67	72.5	6.8	72.5	64.9	54.8	44.7	34.5	-	66.9	7.4	66.9	62.2	52.2	42.3	32.3	-
	62	66.8	6.7	66.8	66.8	66.8	56.6	46.5	36.4	61.6	7.4	61.6	61.6	61.6	51.7	41.7	31.7
	57	67.9	6.7	67.9	67.9	67.9	57.8	47.7	37.5	63.5	7.3	63.5	63.5	63.5	53.6	43.6	33.6

1. These capacities are gross ratings. For net capacity, deduct air blower motor, MBh = 3.415 x kW. Refer to the appropriate Blower Performance Table for the kW of the supply air blower motor.
2. These ratings include the condenser fan motors (total 1 kW) and the compressor motors but not the supply air blower motor.

- No sensible cooling capacity

ZT240 (20 ton)

Air on evaporator coil		Temperature of air on condenser coil															
CFM	WB (°F)	Total capacity ¹ (MBh)	Total input (kW) ²	Sensible capacity (MBh)						Total capacity ¹ (MBh)	Total input (kW) ²	Sensible capacity (MBh)					
				Return dry bulb (°F)								Return dry bulb (°F)					
				90	85	80	75	70	65			90	85	80	75	70	65
				75°F						85°F							
5000	77	315.5	15.4	130.6	109.4	88.2	-	-	-	299.1	17.6	125.6	104.3	83.1	-	-	-
	72	293.7	15.2	166.5	145.3	124.2	103.0	-	-	277.3	17.3	161.8	140.5	119.3	98.0	-	-
	67	271.9	15.0	202.4	181.3	160.1	138.9	117.8	-	255.4	17.0	197.9	176.7	155.5	134.2	113.0	-
	62	247.4	14.7	247.4	220.3	193.0	171.8	150.7	129.5	232.7	16.7	232.7	217.6	188.0	166.7	145.5	124.2
6000	77	320.5	15.6	143.4	119.6	95.8	-	-	-	305.6	17.7	137.9	114.0	90.1	-	-	-
	72	298.4	15.4	182.4	158.6	134.8	110.9	-	-	283.3	17.4	177.1	153.2	129.3	105.4	-	-
	67	276.2	15.2	221.4	197.6	173.8	150.0	126.1	-	260.9	17.1	216.4	192.5	168.6	144.7	120.8	-
	62	251.3	14.9	251.3	233.3	209.4	185.6	161.8	138.0	237.8	16.8	237.8	227.7	203.8	179.9	156.0	132.1
	57	247.9	14.8	247.9	247.9	220.9	197.1	173.3	149.5	232.0	16.7	232.0	232.0	209.4	185.5	161.6	137.7
7000	77	325.5	15.7	156.2	129.7	103.3	-	-	-	312.1	17.8	150.2	123.6	97.1	-	-	-
	72	303.0	15.5	198.3	171.8	145.4	118.9	-	-	289.3	17.6	192.5	165.9	139.4	112.8	-	-
	67	280.5	15.3	240.4	213.9	187.4	161.0	134.5	-	266.5	17.3	234.8	208.2	181.7	155.1	128.6	-
	62	255.2	15.0	255.2	246.2	225.9	199.4	173.0	146.5	242.8	17.0	242.8	237.8	219.7	193.1	166.5	140.0
	57	251.8	15.0	251.8	251.8	238.3	211.8	185.4	158.9	237.0	16.9	237.0	237.0	225.6	199.1	172.5	146.0
8000	77	330.4	15.9	169.0	139.9	110.8	-	-	-	318.6	18.0	162.5	133.3	104.1	-	-	-
	72	307.6	15.7	214.2	185.1	155.9	126.8	-	-	295.3	17.7	207.9	178.6	149.4	120.2	-	-
	67	284.8	15.5	259.3	230.2	201.1	172.0	142.8	-	272.0	17.4	253.2	224.0	194.8	165.6	136.4	-
	62	259.1	15.2	259.1	259.1	242.4	213.2	184.1	155.0	247.9	17.1	247.9	247.9	235.5	206.3	177.1	147.9
	57	255.6	15.1	255.6	255.6	255.6	226.5	197.4	168.3	241.9	17.0	241.9	241.9	241.9	212.7	183.5	154.3
8700	72	313.3	15.8	227.4	196.1	164.9	133.7	-	-	298.3	17.8	219.7	188.6	157.5	126.5	-	-
	67	290.0	15.6	277.3	243.9	212.7	181.4	150.2	-	274.8	17.5	265.4	236.4	205.3	174.3	143.2	-
	62	263.8	15.3	263.8	263.8	255.5	224.2	193.0	161.8	250.4	17.2	250.4	250.4	244.2	213.1	182.0	150.9
	57	260.3	15.2	260.3	260.3	229.0	197.8	166.6	-	244.4	17.1	244.4	244.4	244.4	213.3	182.2	151.1
9400	72	318.9	15.9	240.5	207.2	173.9	140.5	-	-	301.3	17.9	231.6	198.6	165.6	132.7	-	-
	67	295.2	15.6	295.2	257.6	224.2	190.9	157.6	-	277.5	17.6	277.5	248.9	215.9	182.9	150.0	-
	62	268.6	15.4	268.6	268.6	268.6	235.2	201.9	168.6	252.9	17.3	252.9	252.9	252.9	219.9	187.0	154.0
	57	264.9	15.3	264.9	264.9	264.9	231.6	198.2	164.9	246.8	17.2	246.8	246.8	246.8	213.8	180.9	147.9
				95°F						105°F							
5000	77	282.7	19.8	120.6	99.3	77.9	-	-	-	267.3	22.1	110.3	92.1	70.9	-	-	-
	72	260.8	19.4	157.0	135.7	114.4	93.0	-	-	245.3	21.7	149.7	128.6	107.5	86.3	-	-
	67	238.9	19.0	193.4	172.1	150.8	129.5	108.2	-	223.2	21.3	189.2	165.1	144.0	122.9	101.7	-
	62	218.1	18.7	218.1	214.9	182.9	161.6	140.3	119.0	203.7	21.0	203.7	202.1	170.6	149.4	128.3	107.2
6000	77	290.8	19.9	132.4	108.4	84.4	-	-	-	274.0	22.2	124.7	100.9	77.1	-	-	-
	72	268.2	19.5	171.8	147.9	123.9	99.9	-	-	251.4	21.8	164.4	140.6	116.8	93.0	-	-
	67	245.6	19.1	211.3	187.3	163.4	139.4	115.4	-	228.8	21.4	204.1	180.3	156.5	132.7	108.9	-
	62	224.3	18.8	224.3	222.1	198.2	174.2	150.2	126.2	208.8	21.1	208.8	207.7	185.4	161.6	137.8	114.0
	57	216.2	18.7	216.2	216.2	197.8	173.8	149.8	125.9	205.1	21.1	205.1	205.1	185.5	161.7	137.9	114.1
7000	77	298.8	20.0	144.2	117.6	90.9	-	-	-	280.7	22.3	139.1	109.7	83.3	-	-	-
	72	275.6	19.6	186.7	160.0	133.4	106.8	-	-	257.5	21.9	179.1	152.6	126.1	99.7	-	-
	67	252.4	19.2	229.2	202.5	175.9	149.3	122.6	-	234.4	21.5	219.0	195.5	169.0	142.6	116.1	-
	62	230.5	18.9	230.5	229.4	213.4	186.8	160.1	133.5	213.9	21.2	213.9	213.4	200.2	173.7	147.3	120.8
	57	222.2	18.8	222.2	222.2	213.0	186.4	159.7	133.1	210.1	21.2	210.1	210.1	200.3	173.9	147.4	120.9
8000	77	306.8	20.1	156.0	126.7	97.4	-	-	-	287.4	22.4	153.5	118.5	89.4	-	-	-
	72	283.0	19.7	201.5	172.2	142.9	113.6	-	-	263.7	22.0	193.7	164.6	135.5	106.4	-	-
	67	259.2	19.3	247.1	217.8	188.5	159.2	129.9	-	240.0	21.6	233.9	210.7	181.6	152.4	123.3	-
	62	236.7	19.0	236.7	236.7	228.6	199.3	170.0	140.7	219.0	21.3	219.0	219.0	215.0	185.9	156.8	127.7
	57	228.2	18.9	228.2	228.2	228.2	198.9	169.6	140.3	215.1	21.3	215.1	215.1	215.1	186.0	156.9	127.8
8700	72	283.4	19.8	212.1	181.1	150.2	119.2	-	-	264.3	22.1	202.6	172.1	141.5	111.0	-	-
	67	259.5	19.4	253.4	229.0	198.0	167.1	136.1	-	240.6	21.7	237.6	220.2	189.6	159.1	128.6	-
	62	236.9	19.1	236.9	236.9	232.9	202.0	171.0	140.1	219.6	21.4	219.6	219.6	217.6	187.0	156.5	125.9
	57	228.4	19.0	228.4	228.4	228.4	197.5	166.6	135.6	215.7	21.4	215.7	215.7	215.7	185.1	154.6	124.1
9400	72	283.7	19.9	222.6	190.0	157.4	124.8	-	-	265.0	22.3	211.5	179.5	147.6	115.6	-	-
	67	259.8	19.5	259.8	240.2	207.6	175.0	142.4	-	241.2	21.9	241.2	229.7	197.7	165.8	133.8	-
	62	237.2	19.2	237.2	237.2	237.2	204.6	172.0	139.4	220.1	21.6	220.1	220.1	220.1	188.1	156.2	124.2
	57	228.7	19.1	228.7	228.7	228.7	196.1	163.5	130.9	216.2	21.6	216.2	216.2	216.2	184.3	152.3	120.3

ZT240 (20 ton) (continued)

Air on evaporator coil		Temperature of air on condenser coil															
CFM	WB (°F)	Total capacity ¹ (MBh)	Total input (kW) ²	Sensible capacity (MBh)						Total capacity ¹ (MBh)	Total input (kW) ²	Sensible capacity (MBh)					
				Return dry bulb (°F)								Return dry bulb (°F)					
				90	85	80	75	70	65			90	85	80	75	70	65
				115°F						125°F							
5000	77	251.9	24.4	100.0	84.9	64.0	-	-	-	236.4	26.7	86.6	77.7	57.0	-	-	-
	72	229.7	24.0	142.4	121.5	100.6	79.6	-	-	214.2	26.3	135.1	114.4	93.7	72.9	-	-
	67	207.6	23.6	184.9	158.1	137.2	116.2	95.3	-	191.9	25.9	180.9	151.1	130.3	109.6	88.9	-
	62	189.3	23.3	189.3	189.3	158.2	137.2	116.3	95.4	175.0	25.6	175.0	175.0	145.8	125.0	104.3	83.6
6000	77	257.2	24.5	117.0	93.4	69.8	-	-	-	240.4	26.8	109.3	85.9	62.4	-	-	-
	72	234.6	24.1	156.9	133.3	109.7	86.1	-	-	217.8	26.4	149.5	126.0	102.6	79.2	-	-
	67	212.0	23.7	196.9	173.3	149.7	126.0	102.4	-	195.1	26.0	189.6	166.2	142.8	119.4	96.0	-
	62	193.4	23.4	193.4	193.4	172.6	149.0	125.4	101.8	177.9	25.7	177.9	177.9	159.8	136.4	112.9	89.5
7000	77	262.5	24.6	134.0	101.9	75.6	-	-	-	244.4	26.9	132.0	94.0	67.9	-	-	-
	72	239.5	24.2	171.4	145.1	118.9	92.6	-	-	221.4	26.5	163.8	137.7	111.6	85.5	-	-
	67	216.4	23.8	208.8	188.4	162.1	135.9	109.6	-	198.3	26.1	198.3	181.4	155.3	129.2	103.1	-
	62	197.4	23.5	197.4	197.4	187.0	160.7	134.4	108.2	180.8	25.8	180.8	180.8	173.8	147.7	121.6	95.5
8000	77	267.9	24.7	151.1	110.4	81.4	-	-	-	248.4	27.0	154.7	102.2	73.4	-	-	-
	72	244.3	24.3	185.9	157.0	128.0	99.1	-	-	225.0	26.6	178.1	149.3	120.6	91.8	-	-
	67	220.8	23.9	220.8	203.6	174.6	145.7	116.8	-	201.6	26.2	201.6	196.5	167.7	139.0	110.2	-
	62	201.4	23.6	201.4	201.4	201.4	172.4	143.5	114.6	183.7	25.9	183.7	183.7	183.7	159.0	130.2	101.5
8700	77	262.5	24.6	134.0	101.9	75.6	-	-	-	244.4	26.9	132.0	94.0	67.9	-	-	-
	72	245.3	24.5	193.1	163.0	132.9	102.7	-	-	226.3	26.8	183.7	154.0	124.2	94.5	-	-
	67	221.7	24.1	221.7	211.4	181.2	151.1	121.0	-	202.8	26.4	202.8	202.6	172.9	143.1	113.4	-
	62	202.2	23.8	202.2	202.2	202.2	172.1	141.9	111.8	184.8	26.1	184.8	184.8	184.8	157.1	127.4	97.7
9400	77	262.5	24.6	134.0	101.9	75.6	-	-	-	244.4	26.9	132.0	94.0	67.9	-	-	-
	72	246.3	24.7	200.4	169.1	137.7	106.4	-	-	227.7	27.1	189.3	158.6	127.9	97.2	-	-
	67	222.6	24.3	222.6	219.2	187.9	156.5	125.2	-	204.0	26.7	204.0	204.0	178.0	147.3	116.6	-
	62	203.0	24.0	203.0	203.0	203.0	171.7	140.4	109.0	185.9	26.3	185.9	185.9	185.9	155.2	124.5	93.8
9400	77	262.5	24.6	134.0	101.9	75.6	-	-	-	244.4	26.9	132.0	94.0	67.9	-	-	-
	72	246.3	24.7	200.4	169.1	137.7	106.4	-	-	227.7	27.1	189.3	158.6	127.9	97.2	-	-
	67	222.6	24.3	222.6	219.2	187.9	156.5	125.2	-	204.0	26.7	204.0	204.0	178.0	147.3	116.6	-
	62	203.0	24.0	203.0	203.0	203.0	171.7	140.4	109.0	185.9	26.3	185.9	185.9	185.9	155.2	124.5	93.8
9400	77	262.5	24.6	134.0	101.9	75.6	-	-	-	244.4	26.9	132.0	94.0	67.9	-	-	-
	72	246.3	24.7	200.4	169.1	137.7	106.4	-	-	227.7	27.1	189.3	158.6	127.9	97.2	-	-
	67	222.6	24.3	222.6	219.2	187.9	156.5	125.2	-	204.0	26.7	204.0	204.0	178.0	147.3	116.6	-
	62	203.0	24.0	203.0	203.0	203.0	171.7	140.4	109.0	185.9	26.3	185.9	185.9	185.9	155.2	124.5	93.8
9400	77	262.5	24.6	134.0	101.9	75.6	-	-	-	244.4	26.9	132.0	94.0	67.9	-	-	-
	72	246.3	24.7	200.4	169.1	137.7	106.4	-	-	227.7	27.1	189.3	158.6	127.9	97.2	-	-
	67	222.6	24.3	222.6	219.2	187.9	156.5	125.2	-	204.0	26.7	204.0	204.0	178.0	147.3	116.6	-
	62	203.0	24.0	203.0	203.0	203.0	171.7	140.4	109.0	185.9	26.3	185.9	185.9	185.9	155.2	124.5	93.8
9400	77	262.5	24.6	134.0	101.9	75.6	-	-	-	244.4	26.9	132.0	94.0	67.9	-	-	-
	72	246.3	24.7	200.4	169.1	137.7	106.4	-	-	227.7	27.1	189.3	158.6	127.9	97.2	-	-
	67	222.6	24.3	222.6	219.2	187.9	156.5	125.2	-	204.0	26.7	204.0	204.0	178.0	147.3	116.6	-
	62	203.0	24.0	203.0	203.0	203.0	171.7	140.4	109.0	185.9	26.3	185.9	185.9	185.9	155.2	124.5	93.8
9400	77	262.5	24.6	134.0	101.9	75.6	-	-	-	244.4	26.9	132.0	94.0	67.9	-	-	-
	72	246.3	24.7	200.4	169.1	137.7	106.4	-	-	227.7	27.1	189.3	158.6	127.9	97.2	-	-
	67	222.6	24.3	222.6	219.2	187.9	156.5	125.2	-	204.0	26.7	204.0	204.0	178.0	147.3	116.6	-
	62	203.0	24.0	203.0	203.0	203.0	171.7	140.4	109.0	185.9	26.3	185.9	185.9	185.9	155.2	124.5	93.8

1. These capacities are gross ratings. For net capacity, deduct air blower motor, MBh = 3.415 x kW. Refer to the appropriate Blower Performance Table for the kW of the supply air blower motor.
2. These ratings include the condenser fan motors (total 1 kW) and the compressor motors but not the supply air blower motor.

ZT240 (20 ton) optional reheat mode

Air on evaporator coil		Temperature of air on condenser coil															
CFM	WB (°F)	Total capacity ¹ (MBh)	Total input (kW) ²	Sensible capacity (MBh)						Total capacity ¹ (MBh)	Total input (kW) ²	Sensible capacity (MBh)					
				Return dry bulb (°F)								Return dry bulb (°F)					
				90	85	80	75	70	65			90	85	80	75	70	65
		35°F								45°F							
5000	72	96.7	4.7	53.7	44.8	36.0	27.2	-	-	100.1	5.5	43.4	35.6	27.8	20.0	-	-
	67	96.0	4.5	82.1	74.0	65.2	56.4	47.5	-	95.4	5.4	70.6	62.7	54.9	47.1	39.3	-
	62	103.9	4.4	103.9	103.9	91.8	83.0	74.2	65.4	94.9	5.4	94.9	85.1	72.4	64.6	56.7	48.9
6000	72	97.8	4.9	54.4	46.4	38.3	30.2	-	-	102.3	5.6	48.4	39.9	31.5	23.0	-	-
	67	97.1	4.6	84.3	76.2	68.1	60.1	52.0	-	97.5	5.4	79.1	70.7	62.2	53.7	45.3	-
	62	105.3	4.5	105.3	105.3	97.3	89.2	81.1	73.1	97.0	5.4	97.0	90.4	82.0	73.5	65.0	56.6
	57	103.4	4.5	103.4	103.4	95.7	87.6	79.6	71.5	96.3	5.4	96.3	89.9	81.4	72.9	64.5	56.0
7000	72	98.9	5.0	55.2	47.9	40.6	33.3	-	-	104.5	5.6	53.4	44.3	35.2	26.0	-	-
	67	98.3	4.8	86.5	78.4	71.1	63.8	56.5	-	99.6	5.4	87.7	78.6	69.5	60.4	51.3	-
	62	106.7	4.6	106.7	106.7	102.7	95.4	88.1	80.8	99.1	5.4	99.1	95.8	91.6	82.5	73.3	64.2
	57	104.7	4.6	104.7	104.7	100.9	93.6	86.3	79.0	98.4	5.4	98.4	95.2	90.9	81.8	72.7	63.6
8000	72	100.0	5.1	55.9	49.4	42.9	36.3	-	-	106.7	5.6	58.4	48.6	38.8	29.1	-	-
	67	99.4	4.9	88.7	80.6	74.0	67.5	61.0	-	101.7	5.4	96.3	86.5	76.8	67.0	57.2	-
	62	108.2	4.8	108.2	108.2	101.6	95.1	88.5	-	101.2	5.4	101.2	101.2	101.2	91.4	81.6	71.9
	57	106.1	4.8	106.1	106.1	99.6	93.0	86.5	-	100.5	5.4	100.5	100.5	100.5	90.7	80.9	71.2
8700	72	101.5	5.2	55.5	49.8	44.1	38.4	-	-	108.5	5.6	59.2	50.0	40.8	31.6	-	-
	67	101.0	4.9	92.3	81.3	75.6	70.0	64.3	-	103.4	5.4	99.1	89.9	80.7	71.5	62.3	-
	62	109.8	4.8	109.8	109.8	104.1	98.5	92.8	-	102.9	5.4	102.9	102.9	102.9	93.7	84.5	75.3
	57	107.8	4.8	107.8	107.8	102.1	96.4	90.7	-	102.1	5.4	102.1	102.1	102.1	93.0	83.8	74.6
9400	72	103.0	5.2	55.0	50.2	45.3	40.5	-	-	110.3	5.6	60.1	51.4	42.8	34.2	-	-
	67	102.5	5.0	96.0	82.1	77.2	72.4	67.6	-	105.1	5.5	101.9	93.2	84.6	76.0	67.4	-
	62	111.5	4.9	111.5	111.5	111.5	106.7	101.9	97.0	104.6	5.5	104.6	104.6	104.6	96.0	87.3	78.7
	57	109.4	4.9	109.4	109.4	104.6	99.8	94.9	-	103.8	5.5	103.8	103.8	103.8	95.2	86.6	78.0
		55°F								65°F							
5000	72	103.5	6.3	33.2	26.4	19.6	12.8	-	-	98.4	6.9	26.4	20.0	13.5	7.1	-	-
	67	94.9	6.2	59.1	51.5	44.7	37.9	31.1	-	88.8	6.8	54.4	47.6	41.2	34.7	28.3	-
	62	86.0	6.4	79.5	66.2	52.9	46.1	39.3	32.5	80.3	6.9	74.2	61.8	49.3	42.9	36.5	30.0
6000	72	106.8	6.2	42.4	33.5	24.6	15.8	-	-	101.3	6.9	33.6	25.3	17.0	8.7	-	-
	67	97.9	6.2	74.0	65.1	56.3	47.4	38.5	-	91.5	6.8	68.3	60.1	51.8	43.5	35.2	-
	62	88.7	6.3	84.4	75.6	66.7	57.8	48.9	40.1	82.7	6.8	78.6	70.4	62.1	53.8	45.5	37.2
	57	89.3	6.2	84.8	76.0	67.1	58.2	49.4	40.5	83.2	6.8	79.0	70.7	62.5	54.2	45.9	37.6
7000	72	110.1	6.2	51.6	40.7	29.7	18.8	-	-	104.3	6.8	40.8	30.7	20.5	10.4	-	-
	67	100.9	6.1	89.0	78.8	67.9	57.0	46.0	-	94.1	6.7	82.3	72.5	62.4	52.3	42.1	-
	62	91.5	6.2	89.3	84.9	80.4	69.5	58.6	47.7	85.1	6.8	83.1	79.0	74.8	64.7	54.6	44.4
	57	92.0	6.2	89.8	85.4	81.0	70.0	59.1	48.2	85.7	6.7	83.6	79.4	75.3	65.1	55.0	44.9
8000	72	113.4	6.1	60.8	47.8	34.8	21.8	-	-	107.3	6.7	48.0	36.0	24.0	12.1	-	-
	67	103.9	6.0	103.9	92.5	79.5	66.5	53.5	-	96.8	6.6	96.2	85.0	73.0	61.1	49.1	-
	62	94.2	6.1	94.2	94.2	94.2	81.2	68.2	55.2	87.6	6.7	87.6	87.6	87.6	75.6	63.6	51.6
	57	94.8	6.1	94.8	94.8	94.8	81.8	68.8	55.8	88.1	6.7	88.1	88.1	88.1	76.1	64.1	52.2
8700	72	115.5	6.1	63.0	50.3	37.6	24.9	-	-	108.4	6.7	49.9	38.1	26.2	14.3	-	-
	67	105.8	6.0	105.8	98.4	85.7	73.0	60.3	-	97.9	6.6	97.6	91.1	80.1	68.2	56.4	-
	62	95.9	6.1	95.9	95.9	95.9	83.2	70.5	57.8	88.5	6.7	88.5	88.5	88.5	76.6	64.8	52.9
	57	96.5	6.1	96.5	96.5	96.5	83.8	71.1	58.4	89.1	6.6	89.1	89.1	89.1	77.2	65.3	53.4
9400	72	117.6	6.0	65.1	52.7	40.3	27.9	-	-	109.6	6.7	51.9	40.1	28.3	16.6	-	-
	67	107.7	5.9	107.7	104.4	92.0	79.6	67.2	-	98.9	6.6	98.9	97.3	87.2	75.4	63.7	-
	62	97.6	6.1	97.6	97.6	97.6	85.2	72.8	60.4	89.5	6.7	89.5	89.5	89.5	77.7	65.9	54.2
	57	98.3	6.0	98.3	98.3	98.3	85.8	73.4	61.0	90.0	6.6	90.0	90.0	90.0	78.3	66.5	54.7

ZT240 (20 ton) optional reheat mode (continued)

Air on evaporator coil		Temperature of air on condenser coil															
CFM	WB (°F)	Total capacity ¹ (MBh)	Total input (kW) ²	Sensible capacity (MBh)						Total capacity ¹ (MBh)	Total input (kW) ²	Sensible capacity (MBh)					
				Return dry bulb (°F)								Return dry bulb (°F)					
				90	85	80	75	70	65			90	85	80	75	70	65
				75°F						85°F							
5000	72	93.2	7.5	19.6	13.6	7.5	1.4	-	-	88.0	8.1	12.8	7.1	1.5	-4.2	-	-
	67	82.7	7.4	49.8	43.7	37.6	31.6	25.5	-	76.6	8.0	45.1	39.8	34.1	28.4	22.7	-
	62	74.6	7.4	68.8	57.3	45.8	39.7	33.6	27.5	68.9	8.0	63.5	52.8	42.2	36.5	30.8	25.1
6000	72	95.8	7.5	24.8	17.1	9.4	1.7	-	-	90.3	8.1	16.0	8.9	1.8	-5.3	-	-
	67	85.0	7.4	62.7	55.0	47.3	39.6	31.9	-	78.6	8.0	57.0	49.9	42.8	35.7	28.6	-
	62	76.7	7.4	72.9	65.2	57.5	49.8	42.1	34.4	70.7	7.9	67.1	60.0	52.9	45.8	38.6	31.5
	57	77.1	7.3	73.2	65.5	57.8	50.1	42.4	34.7	71.1	7.9	67.4	60.3	53.2	46.0	38.9	31.8
7000	72	98.5	7.4	30.0	20.7	11.3	2.0	-	-	92.6	8.1	19.2	10.7	2.1	-6.4	-	-
	67	87.4	7.3	75.6	66.3	56.9	47.6	38.3	-	80.6	7.9	68.9	60.0	51.4	42.9	34.4	-
	62	78.8	7.3	76.9	73.0	69.2	59.9	50.5	41.2	72.5	7.9	70.7	67.1	63.6	55.0	46.5	38.0
	57	79.3	7.3	77.3	73.4	69.6	60.3	50.9	41.6	72.9	7.9	71.0	67.5	63.9	55.4	46.9	38.3
8000	72	101.1	7.4	35.2	24.2	13.2	2.3	-	-	95.0	8.0	22.4	12.4	2.5	-7.5	-	-
	67	89.7	7.3	88.5	77.5	66.6	55.6	44.6	-	82.6	7.9	80.8	70.1	60.1	50.2	40.2	-
	62	80.9	7.3	80.9	80.9	80.9	70.0	59.0	48.0	74.3	7.9	74.3	74.3	74.3	64.3	54.4	44.4
	57	81.4	7.2	81.4	81.4	81.4	70.4	59.5	48.5	74.7	7.8	74.7	74.7	74.7	64.7	54.8	44.8
8700	72	101.4	7.4	36.9	25.9	14.8	3.8	-	-	94.3	8.0	23.9	13.7	3.5	-6.8	-	-
	67	89.9	7.3	89.3	83.9	74.5	63.5	52.4	-	82.0	7.9	81.1	76.6	68.9	58.7	48.4	-
	62	81.1	7.3	81.1	81.1	81.1	70.1	59.0	48.0	73.7	7.9	73.7	73.7	73.7	63.5	53.3	43.1
	57	81.6	7.2	81.6	81.6	81.6	70.6	59.5	48.5	74.1	7.8	74.1	74.1	74.1	63.9	53.7	43.5
9400	72	101.6	7.4	38.6	27.5	16.4	5.3	-	-	93.7	8.0	25.4	14.9	4.5	-6.0	-	-
	67	90.2	7.3	90.2	90.2	82.4	71.3	60.2	-	81.4	7.9	81.4	81.4	77.6	67.2	56.7	-
	62	81.3	7.3	81.3	81.3	81.3	70.2	59.1	48.0	73.2	7.9	73.2	73.2	73.2	62.7	52.2	41.8
	57	81.8	7.2	81.8	81.8	81.8	70.7	59.6	48.4	73.6	7.9	73.6	73.6	73.6	63.1	52.6	42.1

1. These capacities are gross ratings. For net capacity, deduct air blower motor, MBh = 3.415 x kW. Refer to the appropriate Blower Performance Table for the kW of the supply air blower motor.
2. These ratings include the condenser fan motors (total 1 kW) and the compressor motors but not the supply air blower motor.

- No sensible cooling capacity

ZT276 (23 ton)

Air on evaporator coil		Temperature of air on condenser coil																	
CFM	WB (°F)	Total capacity ¹ (MBh)	Total input (kW) ²	Sensible capacity (MBh)						Total capacity ¹ (MBh)	Total input (kW) ²	Sensible capacity (MBh)							
				Return dry bulb (°F)								Return dry bulb (°F)							
				90	85	80	75	70	65			90	85	80	75	70	65		
				75°F								85°F							
5750	77	361.0	10.7	181.8	153.1	124.3	-	-	-	345.9	11.8	173.4	146.8	120.1	-	-	-		
	72	328.3	10.4	215.6	185.2	154.7	124.3	-	-	313.0	11.5	209.1	179.2	149.2	119.3	-	-		
	67	295.7	10.1	249.4	217.3	185.1	153.3	124.5	-	280.1	11.2	244.9	211.6	178.4	147.9	118.9	-		
	62	267.8	9.9	267.8	244.3	215.5	177.8	155.1	124.9	260.0	11.1	260.0	237.5	207.5	174.3	148.5	119.0		
6900	77	365.2	10.7	199.8	160.9	122.1	-	-	-	347.7	11.8	192.4	154.8	117.1	-	-	-		
	72	334.3	10.5	234.0	197.3	160.5	123.9	-	-	318.1	11.6	227.5	191.0	154.6	118.2	-	-		
	67	303.5	10.2	268.3	233.7	199.1	160.9	125.1	-	288.4	11.3	262.5	227.3	192.1	154.9	118.9	-		
	62	282.3	10.0	282.3	262.9	237.6	194.3	163.0	125.6	273.2	11.2	273.2	255.2	229.6	189.8	156.0	119.3		
	57	261.2	9.9	261.2	261.2	238.5	200.9	163.2	257.9	11.1	257.9	257.9	257.9	230.1	193.2	156.3			
8050	77	369.3	10.8	217.8	168.8	119.8	-	-	-	349.5	11.9	211.5	162.8	114.1	-	-	-		
	72	340.3	10.6	252.4	209.4	166.4	123.4	-	-	323.1	11.7	245.8	202.9	159.9	117.0	-	-		
	67	311.2	10.3	287.1	250.1	213.1	168.4	125.6	-	296.7	11.4	280.1	243.0	205.8	161.8	118.8	-		
	62	296.8	10.2	296.8	281.6	259.7	210.8	170.8	126.4	286.3	11.4	286.3	272.9	251.6	205.3	163.5	119.5		
	57	282.4	10.1	282.4	282.4	261.2	216.0	170.9	275.9	11.3	275.9	275.9	275.9	252.9	208.3	163.7			
9200	77	373.5	10.8	235.8	176.6	117.5	-	-	-	351.3	11.9	230.5	170.8	111.1	-	-	-		
	72	346.3	10.6	270.9	221.6	172.3	123.0	-	-	328.2	11.7	264.1	214.7	165.3	115.9	-	-		
	67	319.0	10.4	305.9	266.5	227.0	176.0	126.2	-	305.0	11.5	297.8	258.6	219.5	168.8	118.7	-		
	62	311.3	10.3	311.3	300.3	281.8	227.3	178.7	127.2	299.4	11.5	299.4	290.6	273.7	220.9	171.0	119.7		
	57	303.6	10.3	303.6	303.6	283.9	231.2	178.5	293.9	11.5	293.9	293.9	293.9	275.6	223.3	171.1			
10350	72	352.2	10.7	289.3	233.7	178.1	122.5	-	-	333.3	11.8	282.5	226.6	170.6	114.7	-	-		
	67	326.8	10.5	324.8	282.9	241.0	183.6	126.8	-	313.3	11.7	313.3	274.3	233.2	175.8	118.7	-		
	62	325.8	10.5	325.8	318.9	303.9	243.7	186.6	127.9	312.6	11.6	312.6	308.3	295.7	236.4	178.5	120.0		
	57	324.8	10.5	324.8	324.8	306.6	246.4	186.2	186.2	311.8	11.6	311.8	311.8	311.8	298.3	238.4	178.5		
11500	72	358.2	10.7	307.7	245.8	183.9	122.1	-	-	338.3	11.9	300.8	238.4	176.0	113.6	-	-		
	67	334.6	10.6	334.6	299.3	255.0	191.2	127.4	-	321.6	11.8	321.6	290.0	246.9	182.7	118.6	-		
	62	340.3	10.6	340.3	337.6	326.0	260.2	194.5	128.7	325.7	11.8	325.7	325.7	317.7	251.9	186.1	120.2		
	57	346.0	10.7	346.0	346.0	329.3	261.6	193.9	193.9	329.8	11.8	329.8	329.8	329.8	321.1	253.5	185.9		
				95°F								105°F							
5750	77	330.7	12.9	165.1	140.5	115.9	-	-	-	303.5	15.2	170.2	142.5	114.8	-	-	-		
	72	297.6	12.6	202.7	173.2	143.8	114.3	-	-	275.9	14.5	201.8	170.4	139.1	107.8	-	-		
	67	264.6	12.3	240.3	206.0	171.7	142.5	113.4	-	248.2	13.8	233.3	198.4	163.4	134.3	105.1	-		
	62	252.2	12.2	252.2	230.6	199.6	170.8	142.0	113.2	239.5	13.8	239.5	218.0	187.8	160.7	133.7	106.7		
6900	77	330.2	12.9	185.1	148.6	112.1	-	-	-	305.5	14.4	177.8	140.7	103.6	-	-	-		
	72	301.8	12.7	220.9	184.8	148.6	112.5	-	-	281.2	14.2	212.5	176.3	140.2	104.1	-	-		
	67	273.4	12.4	256.7	220.9	185.1	148.9	112.7	-	256.8	14.0	247.1	211.9	176.8	140.6	104.3	-		
	62	264.0	12.4	264.0	247.4	221.5	185.3	149.1	112.9	250.1	13.9	250.1	235.9	213.4	177.1	140.7	104.3		
	57	254.6	12.3	254.6	254.6	221.8	185.5	149.3	243.3	13.9	243.3	243.3	243.3	213.5	177.1	140.6			
8050	77	329.7	13.0	205.1	156.8	108.4	-	-	-	307.5	13.6	185.5	138.9	92.4	-	-	-		
	72	306.0	12.8	239.2	196.3	153.5	110.6	-	-	286.5	13.8	223.1	182.2	141.3	100.4	-	-		
	67	282.2	12.6	273.2	235.8	198.5	155.2	112.0	-	265.5	14.1	260.8	225.5	190.2	146.9	103.6	-		
	62	275.8	12.5	275.8	264.2	243.5	199.9	156.2	112.6	260.7	14.1	260.7	253.9	239.1	193.4	147.7	102.0		
	57	269.4	12.5	269.4	269.4	244.5	200.5	156.5	255.9	14.0	255.9	255.9	255.9	239.9	191.8	143.7			
9200	77	329.2	13.0	225.2	164.9	104.7	-	-	-	309.5	12.8	193.1	137.2	81.3	-	-	-		
	72	310.1	12.8	257.4	207.9	158.3	108.7	-	-	291.8	13.5	233.8	188.1	142.4	96.7	-	-		
	67	291.0	12.7	289.7	250.8	211.9	161.6	111.3	-	274.1	14.2	274.1	239.1	203.6	153.2	102.9	-		
	62	287.6	12.7	287.6	281.0	265.5	214.5	163.4	112.3	271.3	14.2	271.3	271.3	264.7	209.7	154.7	99.6		
	57	284.1	12.6	284.1	284.1	267.3	215.5	163.6	268.4	14.2	268.4	268.4	268.4	266.2	206.5	146.8			
10350	72	314.3	12.9	275.7	219.4	163.2	106.9	-	-	297.1	13.2	244.5	194.0	143.5	93.0	-	-		
	67	299.9	12.8	299.9	265.7	225.3	168.0	110.6	-	282.7	14.4	282.7	252.6	217.0	159.5	102.1	-		
	62	299.3	12.8	299.3	297.7	287.5	229.0	170.5	112.0	281.9	14.3	281.9	281.9	281.9	226.0	161.7	97.3		
	57	298.8	12.8	298.8	298.8	290.1	230.4	170.8	170.8	281.0	14.3	281.0	281.0	281.0	281.0	221.2	149.9		
11500	72	318.4	13.0	293.9	231.0	168	105.0	-	-	302.4	12.9	255.2	199.9	144.6	89.4	-	-		
	67	308.7	12.9	308.7	280.7	238.8	174.3	109.9	-	291.3	14.5	291.3	266.2	230.3	165.9	101.4	-		
	62	311.1	12.9	311.1	311.1	309.5	243.6	177.6	111.7	292.4	14.5	292.4	292.4	292.4	242.4	168.7	95.0		
	57	313.6	12.9	313.6	313.6	313.6	312.8	245.4	178.0	293.5	14.5	293.5	293.5	293.5	293.5	235.9	153.0		

ZT276 (23 ton) (continued)

Air on evaporator coil		Temperature of air on condenser coil															
		Total capacity ¹ (MBh)	Total input (kW) ²	Sensible capacity (MBh)						Total capacity ¹ (MBh)	Total input (kW) ²	Sensible capacity (MBh)					
				Return dry bulb (°F)								Return dry bulb (°F)					
				90	85	80	75	70	65			90	85	80	75	70	65
		115°F									125°F						
5750	77	276.3	17.5	175.4	144.5	113.7	-	-	-	249.1	19.9	180.5	146.6	112.6	-	-	-
	72	254.1	16.4	200.9	167.7	134.5	101.3	-	-	232.3	18.3	200.0	164.9	129.8	94.8	-	-
	67	231.8	15.3	226.4	190.8	155.2	126.0	96.7	-	215.5	16.8	215.5	183.2	147.0	117.7	88.4	-
	62	226.7	15.3	226.7	205.3	176.0	150.7	125.4	100.1	213.9	16.8	213.9	192.6	164.2	140.7	117.1	93.6
6900	77	280.8	15.9	170.6	132.8	95.1	-	-	-	256.1	17.4	163.3	124.9	86.6	-	-	-
	72	260.5	15.7	204.0	167.9	131.8	95.7	-	-	239.9	17.2	195.5	159.5	123.4	87.4	-	-
	67	240.3	15.5	237.4	203.0	168.6	132.3	96.0	-	223.7	17.0	223.7	194.0	160.3	124.0	87.6	-
	62	236.1	15.4	236.1	224.5	205.3	168.8	132.3	95.7	222.2	17.0	222.2	213.0	197.2	160.5	123.8	87.2
57	232.0	15.4	232.0	232.0	205.3	168.6	131.8	-	220.6	17.0	220.6	220.6	220.6	197.1	160.1	123.1	
8050	77	285.3	14.3	165.8	121.1	76.5	-	-	-	263.1	14.9	146.1	103.3	60.5	-	-	-
	72	267.0	14.9	207.1	168.1	129.2	90.2	-	-	247.5	16.0	191.1	154.0	117.0	80.0	-	-
	67	248.7	15.6	248.4	215.2	181.9	138.6	95.2	-	231.9	17.1	231.9	204.8	173.6	130.2	86.8	-
	62	245.5	15.6	245.5	243.7	234.6	186.9	139.1	91.4	230.4	17.1	230.4	230.4	230.2	180.4	130.6	80.7
57	242.4	15.6	242.4	242.4	235.2	183.0	130.9	-	228.9	17.1	228.9	228.9	228.9	228.9	174.3	118.1	
9200	77	289.8	12.6	161.0	109.4	57.8	-	-	-	270.1	12.4	128.9	81.6	34.4	-	-	-
	72	273.5	14.2	210.2	168.4	126.5	84.7	-	-	255.1	14.9	186.6	148.6	110.6	72.7	-	-
	67	257.1	15.8	257.1	227.3	195.2	144.8	94.4	-	240.2	17.3	240.2	215.6	186.9	136.5	86.0	-
	62	254.9	15.7	254.9	254.9	254.9	205.0	146.0	87.0	238.6	17.3	238.6	238.6	238.6	200.2	137.3	74.3
57	252.8	15.7	252.8	252.8	252.8	252.8	197.5	129.9	237.1	17.3	237.1	237.1	237.1	237.1	188.5	113.1	
10350	72	279.9	13.4	213.3	168.6	123.9	79.2	-	-	262.8	13.7	182.1	143.2	104.3	65.3	-	-
	67	265.6	15.9	265.6	239.5	208.6	151.1	93.7	-	248.4	17.4	248.4	226.4	200.2	142.7	85.2	-
	62	264.4	15.9	264.4	264.4	264.4	223.1	152.8	82.6	246.9	17.4	246.9	246.9	246.9	220.1	144.0	67.9
	57	263.1	15.9	263.1	263.1	263.1	263.1	212.0	129.0	245.3	17.4	245.3	245.3	245.3	245.3	202.8	108.1
11500	72	286.4	12.7	216.4	168.8	121.2	73.7	-	-	270.4	12.5	177.6	137.8	97.9	58.0	-	-
	67	274.0	16.0	274.0	251.7	221.9	157.4	92.9	-	256.7	17.6	256.7	237.1	213.5	148.9	84.4	-
	62	273.8	16.0	273.8	273.8	273.8	241.1	159.7	78.2	255.1	17.6	255.1	255.1	255.1	239.9	150.7	61.5
	57	273.5	16.0	273.5	273.5	273.5	273.5	226.5	128.1	253.5	17.6	253.5	253.5	253.5	253.5	217.0	103.1

1. These capacities are gross ratings. For net capacity, deduct air blower motor, MBh = 3.415 x kW. Refer to the appropriate Blower Performance Table for the kW of the supply air blower motor.
2. These ratings include the condenser fan motors (total 1 kW) and the compressor motors but not the supply air blower motor.

ZT276 (23 ton) optional reheat mode

Air on evaporator coil		Temperature of air on condenser coil															
CFM	WB (°F)	Total capacity ¹ (MBh)	Total input (kW) ²	Sensible capacity (MBh)						Total capacity ¹ (MBh)	Total input (kW) ²	Sensible capacity (MBh)					
				Return dry bulb (°F)								Return dry bulb (°F)					
				90	85	80	75	70	65			90	85	80	75	70	65
				35°F						45°F							
5750	72	108.5	5.2	59.9	49.9	40.0	30.0	-	-	113.3	6.0	51.8	42.9	34.0	25.1	-	-
	67	110.4	4.8	96.3	86.3	76.3	66.3	56.4	-	108.5	5.9	82.1	73.2	64.4	55.5	46.6	-
	62	110.7	4.7	110.7	107.9	92.7	82.7	72.7	62.7	105.2	5.9	105.2	97.6	84.4	75.5	66.6	57.8
6900	72	109.3	5.2	63.0	53.1	43.1	33.2	-	-	114.7	6.0	55.5	46.4	37.2	28.1	-	-
	67	111.3	4.8	102.3	92.4	82.4	72.5	62.5	-	109.8	5.9	88.7	79.5	70.4	61.3	52.1	-
	62	111.7	4.7	111.7	109.8	99.8	89.9	80.0	70.0	106.5	5.9	106.5	101.4	92.3	83.2	74.0	64.9
	57	110.8	4.8	110.8	108.6	98.6	88.7	78.8	68.8	106.2	5.9	106.2	102.0	92.9	83.7	74.6	65.4
8050	72	110.1	5.2	66.1	56.2	46.3	36.4	-	-	116.1	6.0	59.2	49.8	40.4	31.0	-	-
	67	112.3	4.8	108.3	98.4	88.5	78.6	68.7	-	111.2	5.9	95.3	85.9	76.4	67.0	57.6	-
	62	112.6	4.7	112.6	111.7	107.0	97.1	87.2	77.3	107.8	5.9	107.8	105.3	100.2	90.8	81.4	72.0
	57	111.7	4.8	111.7	110.6	105.7	95.7	85.8	75.9	107.5	5.9	107.5	105.4	100.8	91.4	82.0	72.6
9200	72	111.0	5.3	69.2	59.4	49.5	39.6	-	-	117.5	5.9	63.0	53.3	43.6	33.9	-	-
	67	113.2	4.8	113.2	104.5	94.6	84.7	74.8	-	112.5	5.8	101.9	92.2	82.5	72.8	63.1	-
	62	113.6	4.8	113.6	113.6	113.6	104.3	94.4	84.5	109.1	5.8	109.1	109.1	108.1	98.4	88.7	79.0
	57	112.7	4.8	112.7	112.7	112.7	102.8	92.9	83.0	108.8	5.9	108.8	108.8	108.8	99.1	89.4	79.7
10350	72	108.5	5.3	67.0	58.8	50.7	42.5	-	-	118.7	6.0	69.1	59.3	49.5	39.8	-	-
	67	111.1	4.9	111.1	106.7	97.1	89.0	80.8	-	113.7	5.9	108.4	103.5	93.7	84.0	74.2	-
	62	111.7	4.8	111.7	111.7	111.7	103.8	95.7	87.5	110.2	5.9	110.2	110.2	109.8	100.0	90.2	80.5
	57	110.7	4.9	110.7	110.7	110.7	102.6	94.4	86.3	109.9	5.9	109.9	109.9	109.9	100.2	90.4	80.6
11500	72	106.0	5.4	64.7	58.3	51.8	45.4	-	-	119.9	6.0	75.1	65.3	55.5	45.7	-	-
	67	109.0	5.0	109.0	108.9	99.6	93.2	86.8	-	114.9	5.9	114.9	114.8	105.0	95.2	85.3	-
	62	109.8	4.9	109.8	109.8	109.8	103.4	97.0	90.5	111.4	5.9	111.4	111.4	111.4	101.6	91.7	81.9
	57	108.8	5.0	108.8	108.8	108.8	102.4	96.0	89.6	111.0	5.9	111.0	111.0	111.0	101.2	91.4	81.6
				55°F						65°F							
5750	72	118.1	6.7	43.6	35.8	28.1	20.3	-	-	113.6	7.6	34.6	27.2	19.8	12.5	-	-
	67	106.6	7.0	67.9	60.2	52.4	44.6	36.9	-	101.4	7.7	63.2	55.8	48.4	41.1	33.7	-
	62	99.7	7.0	99.7	87.3	76.1	68.3	60.5	52.8	94.0	7.7	91.9	79.8	68.2	60.8	53.4	46.0
6900	72	120.1	6.7	48.0	39.6	31.3	22.9	-	-	115.8	7.6	38.8	30.7	22.5	14.4	-	-
	67	108.3	6.9	75.1	66.7	58.4	50.0	41.7	-	103.4	7.7	71.9	63.8	55.6	47.5	39.3	-
	62	101.3	7.0	101.3	93.1	84.7	76.4	68.1	59.7	95.8	7.7	94.4	86.3	78.2	70.0	61.9	53.7
	57	101.6	7.0	101.6	95.4	87.1	78.7	70.4	62.0	96.7	7.6	95.1	88.1	79.9	71.7	63.6	55.4
8050	72	122.0	6.7	52.3	43.4	34.5	25.6	-	-	118.0	7.6	43.1	34.2	25.2	16.3	-	-
	67	110.1	6.9	82.2	73.3	64.4	55.4	46.5	-	105.3	7.6	80.6	71.7	62.8	53.9	44.9	-
	62	103.0	7.0	103.0	98.9	93.4	84.5	75.6	66.7	97.6	7.7	96.9	92.9	88.2	79.3	70.4	61.4
	57	103.2	6.9	103.2	100.2	96.0	87.1	78.1	69.2	98.5	7.6	97.7	94.2	90.1	81.2	72.3	63.4
9200	72	124.0	6.6	56.7	47.2	37.7	28.2	-	-	120.2	7.5	47.3	37.6	27.9	18.3	-	-
	67	111.9	6.8	89.4	79.9	70.4	60.8	51.3	-	107.3	7.6	89.3	79.6	69.9	60.3	50.6	-
	62	104.6	6.9	104.6	104.6	102.1	92.6	83.1	73.6	99.5	7.6	99.5	99.5	98.2	88.5	78.8	69.2
	57	104.9	6.9	104.9	104.9	104.9	95.4	85.9	76.4	100.3	7.6	100.3	100.3	100.3	90.6	81.0	71.3
10350	72	128.9	6.6	71.2	59.8	48.4	37.0	-	-	124.0	7.5	57.6	46.5	35.4	24.2	-	-
	67	116.3	6.8	105.1	100.3	90.4	79.0	67.6	-	110.7	7.6	101.7	96.9	87.8	76.7	65.6	-
	62	108.8	6.9	108.8	108.8	107.6	96.2	84.8	73.4	102.6	7.6	102.6	102.6	102.0	90.8	79.7	68.6
	57	109.1	6.8	109.1	109.1	109.1	97.7	86.3	75.0	103.5	7.5	103.5	103.5	103.5	92.4	81.2	70.1
11500	72	133.9	6.5	85.6	72.4	59.1	45.9	-	-	127.8	7.5	68.0	55.4	42.8	30.2	-	-
	67	120.8	6.7	120.8	120.8	110.4	97.2	83.9	-	114.1	7.5	114.1	114.1	105.7	93.1	80.5	-
	62	113.0	6.8	113.0	113.0	113.0	99.7	86.5	73.3	105.8	7.6	105.8	105.8	105.8	93.2	80.6	68.0
	57	113.3	6.8	113.3	113.3	113.3	100.0	86.8	73.6	106.7	7.5	106.7	106.7	106.7	94.1	81.5	68.9

ZT276 (23 ton) optional reheat mode (continued)

Air on evaporator coil		Temperature of air on condenser coil															
CFM	WB (°F)	Total capacity ¹ (MBh)	Total input (kW) ²	Sensible capacity (MBh)						Total capacity ¹ (MBh)	Total input (kW) ²	Sensible capacity (MBh)					
				Return dry bulb (°F)								Return dry bulb (°F)					
				90	85	80	75	70	65			90	85	80	75	70	65
				75°F						85°F							
5750	72	109.2	8.5	25.7	18.6	11.6	4.6	-	-	104.7	9.4	16.7	10.1	3.4	-3.2	-	-
	67	96.2	8.4	58.5	51.5	44.5	37.5	30.5	-	91.1	9.2	53.8	47.2	40.5	33.9	27.3	-
	62	88.3	8.4	84.2	72.3	60.3	53.3	46.3	39.3	82.7	9.1	76.5	64.7	52.4	45.8	39.2	32.5
6900	72	111.6	8.5	29.7	21.8	13.8	5.8	-	-	107.4	9.4	20.6	12.8	5.1	-2.7	-	-
	67	98.4	8.4	68.8	60.8	52.8	44.9	36.9	-	93.4	9.1	65.6	57.8	50.1	42.3	34.5	-
	62	90.3	8.4	87.6	79.6	71.6	63.7	55.7	47.8	84.8	9.1	80.7	72.8	65.1	57.3	49.5	41.8
	57	91.7	8.3	88.7	80.7	72.7	64.8	56.8	48.9	86.8	9.0	82.2	73.4	65.6	57.8	50.1	42.3
8050	72	114.1	8.5	33.8	24.9	16.0	7.1	-	-	110.1	9.4	24.5	15.6	6.7	-2.1	-	-
	67	100.6	8.4	79.0	70.1	61.2	52.3	43.4	-	95.8	9.1	77.4	68.5	59.6	50.7	41.8	-
	62	92.3	8.4	90.9	86.9	83.0	74.0	65.1	56.2	86.9	9.1	84.9	81.0	77.7	68.8	59.9	51.0
	57	93.7	8.3	92.2	88.2	84.2	75.3	66.4	57.5	89.0	9.0	86.7	82.3	78.4	69.5	60.6	51.7
9200	72	116.5	8.4	37.9	28.0	18.2	8.3	-	-	112.8	9.3	28.4	18.4	8.4	-1.6	-	-
	67	102.7	8.3	89.2	79.4	69.5	59.7	49.8	-	98.2	9.1	89.2	79.2	69.1	59.1	49.1	-
	62	94.3	8.3	94.3	94.3	94.3	84.4	74.6	64.7	89.1	9.1	89.1	89.1	89.1	80.3	70.3	60.3
	57	95.7	8.3	95.7	95.7	95.7	85.9	76.0	66.2	91.1	9.0	91.1	91.1	91.1	81.1	71.1	61.1
10350	72	119.2	8.4	44.1	33.2	22.3	11.4	-	-	114.3	9.4	30.6	19.9	9.2	-1.5	-	-
	67	105.1	8.3	98.3	93.4	85.3	74.4	63.5	-	99.4	9.1	94.9	89.9	82.8	72.1	61.4	-
	62	96.4	8.3	96.4	96.4	96.4	85.5	74.6	63.7	90.2	9.1	90.2	90.2	90.2	80.2	69.5	58.8
	57	97.9	8.3	97.9	97.9	97.9	87.0	76.1	65.2	92.3	9.0	92.3	92.3	92.3	81.6	71.0	60.3
11500	72	121.8	8.4	50.4	38.4	26.4	14.4	-	-	115.8	9.4	32.8	21.4	10.1	-1.3	-	-
	67	107.4	8.3	107.4	107.4	101.1	89.1	77.1	-	100.7	9.1	100.7	100.7	96.4	85.1	73.7	-
	62	98.6	8.3	98.6	98.6	98.6	86.6	74.6	62.6	91.4	9.1	91.4	91.4	91.4	80.0	68.6	57.3
	57	100.1	8.3	100.1	100.1	100.1	88.1	76.1	64.2	93.5	9.0	93.5	93.5	93.5	82.2	70.8	59.4

1. These capacities are gross ratings. For net capacity, deduct air blower motor, MBh = 3.415 x kW. Refer to the appropriate Blower Performance Table for the kW of the supply air blower motor.
2. These ratings include the condenser fan motors (total 1 kW) and the compressor motors but not the supply air blower motor.

- No sensible cooling capacity

Airflow performance

ZT180-276 side duct application

ZT180 (15 ton) side duct

Air flow (CFM)	Available external static pressure - IWG ¹																									
	0.4		0.6		0.8		1		1.2		1.4		1.6		1.8		2		2.2		2.4		2.6			
	RPM	BHP	RPM	BHP	RPM	BHP	RPM	BHP	RPM	BHP	RPM	BHP	RPM	BHP	RPM	BHP	RPM	BHP	RPM	BHP	RPM	BHP	RPM	BHP	RPM	BHP
	Standard 5 HP and field supplied drive												Standard 5 HP and drive						High static 7.5 HP and drive							
4000	637	0.68	676	1.02	714	1.35	752	1.67	789	1.97	826	2.27	862	2.56	898	2.85	934	3.12	970	3.39	1005	3.66	1040	3.92		
4400	656	1.05	694	1.39	732	1.72	770	2.03	807	2.34	844	2.64	881	2.93	917	3.21	953	3.49	988	3.76	1023	4.03	1058	4.29		
4800	678	1.44	716	1.78	754	2.11	792	2.43	829	2.73	866	3.03	902	3.32	938	3.61	974	3.88	1010	4.15	1045	4.42	1080	4.68		
5200	702	1.87	740	2.21	778	2.54	816	2.86	853	3.16	890	3.46	927	3.75	963	4.04	999	4.31	1034	4.58	1069	4.85	1104	5.11		
5600	728	2.34	767	2.68	805	3.01	842	3.33	880	3.64	916	3.93	953	4.23	989	4.51	1025	4.79	1061	5.06	1096	5.32	1131	5.58		
6000	756	2.86	795	3.20	833	3.53	871	3.85	908	4.15	945	4.45	981	4.74	1017	5.03	1053	5.30	1089	5.57	1124	5.84	1159	6.10		
6400	786	3.43	824	3.77	862	4.10	900	4.41	937	4.72	974	5.02	1011	5.31	1047	5.59	1083	5.87	1118	6.14	1153	6.41	1188	6.67		
6800	817	4.05	855	4.38	893	4.71	931	5.03	968	5.34	1005	5.64	1041	5.93	1078	6.21	1113	6.49	1149	6.76	1184	7.02	1219	7.29		
7200	848	4.71	887	5.05	925	5.38	962	5.70	1000	6.00	1037	6.30	1073	6.59	1109	6.88	1145	7.15	1181	7.42	1216	7.69	1251	7.95		
7600	881	5.43	919	5.77	957	6.09	995	6.41	1032	6.72	1069	7.02	1106	7.31	1142	7.59	1178	7.87	1213	8.14	1248	8.40	-	-		
	High static 7.5 HP and field supplied drive																									

1. Blower performance includes gas heat exchangers and 2-inch filters. See the static resistance table for additional applications.
2. See the RPM selection table to determine the required motor sheave setting and to determine the maximum continuous BHP.
3. kW = BHP x 0.833.

ZT210 (17.5 ton) side duct

Air flow (CFM)	Available external static pressure - IWG ¹																									
	0.4		0.6		0.8		1		1.2		1.4		1.6		1.8		2		2.2		2.4		2.6			
	RPM	BHP	RPM	BHP	RPM	BHP	RPM	BHP	RPM	BHP	RPM	BHP	RPM	BHP	RPM	BHP	RPM	BHP	RPM	BHP	RPM	BHP	RPM	BHP	RPM	BHP
	Standard static 7.5 HP and field supplied drive												Standard 7.5 HP and drive													
4400	635	0.86	670	1.17	704	1.49	737	1.81	770	2.13	803	2.45	835	2.78	867	3.11	899	3.44	930	3.78	961	4.12	992	4.47		
4800	650	1.22	684	1.53	719	1.85	752	2.17	785	2.49	818	2.81	850	3.14	882	3.47	913	3.80	945	4.14	976	4.48	1007	4.83		
5200	668	1.61	702	1.93	737	2.24	770	2.56	803	2.88	836	3.21	868	3.53	900	3.86	931	4.19	963	4.53	994	4.87	1025	5.22		
5600	689	2.05	723	2.37	757	2.68	791	3.00	824	3.32	856	3.64	889	3.97	921	4.30	952	4.63	984	4.97	1015	5.31	1046	5.66		
6000	711	2.54	746	2.85	780	3.17	814	3.49	847	3.81	879	4.13	912	4.46	944	4.79	975	5.12	1007	5.46	1038	5.80	1069	6.15		
6400	736	3.08	771	3.39	805	3.71	839	4.03	872	4.35	904	4.67	937	5.00	968	5.33	1000	5.66	1031	6.00	1063	6.34	1094	6.69		
6800	763	3.68	798	3.99	832	4.31	865	4.63	898	4.95	931	5.27	963	5.60	995	5.93	1027	6.26	1058	6.60	1089	6.94	1120	7.29		
7200	791	4.33	825	4.65	860	4.96	893	5.28	926	5.60	959	5.92	991	6.25	1023	6.58	1054	6.91	1086	7.25	1117	7.59	1148	7.94		
7600	820	5.04	855	5.36	889	5.67	922	5.99	955	6.31	988	6.64	1020	6.96	1052	7.29	1084	7.63	1115	7.96	1146	8.31	1177	8.65		
8000	850	5.81	885	6.13	919	6.44	952	6.76	986	7.08	1018	7.40	1050	7.73	1082	8.06	1114	8.39	1145	8.73	1176	9.07	1207	9.42		
8400	881	6.64	916	6.95	950	7.27	984	7.59	1017	7.91	1049	8.23	1082	8.56	1113	8.88	1145	9.22	1176	9.56	1208	9.90	1239	10.25		
8800	913	7.52	948	7.83	982	8.15	1016	8.47	1049	8.79	1081	9.11	1114	9.44	1145	9.76	1177	10.10	1208	10.44	1240	10.78	1271	11.13		
	High static 10 HP and drive												High static 10 HP and field supplied drive													

1. Blower performance includes gas heat exchangers and 2-inch filters. See the static resistance table for additional applications.
2. See the RPM selection table to determine the required motor sheave setting and to determine the maximum continuous BHP.
3. kW = BHP x 0.813.

ZT240 (20 ton) side duct

Air flow (CFM)	Available external static pressure - IWG ¹																								
	0.4		0.6		0.8		1		1.2		1.4		1.6		1.8		2		2.2		2.4		2.6		
	RPM	BHP	RPM	BHP	RPM	BHP	RPM	BHP	RPM	BHP	RPM	BHP	RPM	BHP	RPM	BHP	RPM	BHP	RPM	BHP	RPM	BHP	RPM	BHP	RPM
	Standard static 7.5 HP and field supplied drive										Standard 7.5 HP and drive														
5200	668	1.61	702	1.93	737	2.24	770	2.56	803	2.88	836	3.21	868	3.53	900	3.86	931	4.19	963	4.53	994	4.87	1025	5.22	
5600	689	2.05	723	2.37	757	2.68	791	3.00	824	3.32	856	3.64	889	3.97	921	4.30	952	4.63	984	4.97	1015	5.31	1046	5.66	
6000	711	2.54	746	2.85	780	3.17	814	3.49	847	3.81	879	4.13	912	4.46	944	4.79	975	5.12	1007	5.46	1038	5.80	1069	6.15	
6400	736	3.08	771	3.39	805	3.71	839	4.03	872	4.35	904	4.67	937	5.00	968	5.33	1000	5.66	1031	6.00	1063	6.34	1094	6.69	
6800	763	3.68	798	3.99	832	4.31	865	4.63	898	4.95	931	5.27	963	5.60	995	5.93	1027	6.26	1058	6.60	1089	6.94	1120	7.29	
7200	791	4.33	825	4.65	860	4.96	893	5.28	926	5.60	959	5.92	991	6.25	1023	6.58	1054	6.91	1086	7.25	1117	7.59	1148	7.94	
7600	820	5.04	855	5.36	889	5.67	922	5.99	955	6.31	988	6.64	1020	6.96	1052	7.29	1084	7.63	1115	7.96	1146	8.31	1177	8.65	
8000	850	5.81	885	6.13	919	6.44	952	6.76	986	7.08	1018	7.40	1050	7.73	1082	8.06	1114	8.39	1145	8.73	1176	9.07	1207	9.42	
8400	881	6.64	916	6.95	950	7.27	984	7.59	1017	7.91	1049	8.23	1082	8.56	1113	8.88	1145	9.22	1176	9.56	1208	9.90	1239	10.25	
8800	913	7.52	948	7.83	982	8.15	1016	8.47	1049	8.79	1081	9.11	1114	9.44	1145	9.76	1177	10.10	1208	10.44	1240	10.78	1271	11.13	
9200	946	8.45	981	8.77	1015	9.08	1049	9.40	1082	9.72	1114	10.04	1146	10.37	1178	10.70	1210	11.03	1241	11.37	-	-	-	-	
9600	980	9.44	1014	9.75	1048	10.07	1082	10.39	1115	10.71	1148	11.03	1180	11.36	-	-	-	-	-	-	-	-	-	-	
	High static 10 HP and drive										High static 10 HP and field supplied drive														

1. Blower performance includes gas heat exchangers and 2-inch filters. See the static resistance table for additional applications.
2. See the RPM selection table to determine the required motor sheave setting and to determine the maximum continuous BHP.
3. kW = BHP x 0.813.

ZT276 (23 ton) side duct

Air Flow (CFM)	Available external static pressure - IWG ¹																												
	0.4		0.6		0.8		1		1.2		1.4		1.6		1.8		2		2.2		2.4		2.6		2.8		3		
	RPM	BHP	RPM	BHP	RPM	BHP	RPM	BHP	RPM	BHP	RPM	BHP	RPM	BHP	RPM	BHP	RPM	BHP	RPM	BHP	RPM	BHP	RPM	BHP	RPM	BHP	RPM	BHP	RPM
	Low static 7.5 HP and field supplied drive						Low static 7.5 HP and drive						Standard static 10 HP and drive																
6600	780	2.75	811	3.40	841	3.96	887	4.45	900	4.88	930	5.28	960	5.64	990	5.99	1021	6.35	1053	6.72	1085	7.12	1120	7.57	1156	8.08	1193	8.67	
7000	800	3.43	831	4.08	861	4.64	891	5.13	920	5.56	950	5.95	980	6.32	1010	6.67	1041	7.02	1073	7.40	1106	7.80	1140	8.25	1176	8.76	1213	9.35	
7400	822	4.16	853	4.81	886	5.38	913	5.87	942	6.30	972	6.69	1002	7.06	1032	7.41	1063	7.76	1095	8.13	1128	8.54	1162	8.99	1198	9.50	1235	10.09	
7800	846	4.96	885	5.61	907	6.17	936	6.66	966	7.10	995	7.49	1025	7.85	1055	8.20	1086	8.56	1118	8.93	1151	9.33	1185	9.78	1221	10.30	1259	10.88	
8200	883	5.81	902	6.46	932	7.03	962	7.52	991	7.95	1021	8.34	1050	8.71	1081	9.06	1112	9.41	1143	9.78	1176	10.19	1211	10.64	1247	11.15	1284	11.74	
8600	898	6.72	929	7.37	959	7.94	989	8.43	1018	8.86	1048	9.25	1077	9.62	1108	9.97	1139	10.32	1170	10.69	1203	11.10	1238	11.55	1273	12.06	1311	12.65	
9000	926	7.69	957	8.34	987	8.90	1017	9.39	1047	9.82	1076	10.22	1106	10.59	1136	10.93	1167	11.29	1199	11.66	1232	12.06	1266	12.51	1302	13.02	1340	13.61	
9400	956	8.61	987	9.35	1017	9.92	1047	10.41	1077	10.84	1106	11.23	1136	11.60	1166	11.95	1197	12.30	1229	12.67	1262	13.08	1296	13.53	1332	14.04	1370	14.63	
9800	986	9.77	1019	10.42	1049	10.99	1079	11.48	1108	11.91	1138	12.30	1168	12.67	1198	13.02	1229	13.37	1261	13.74	1293	14.15	1328	14.60	1364	15.11	1401	15.70	
10200	1021	10.89	1052	11.49	1082	12.11	1112	12.60	1141	13.03	1171	13.42	1201	13.79	1231	14.14	1262	14.49	1294	14.86	1327	15.27	1361	15.72	1397	16.23	1434	16.82	
10600	1056	11.49	1087	12.71	1117	13.27	1146	13.77	1176	14.20	1205	14.59	1235	14.95	1266	15.31	1296	15.66	1328	16.03	1361	16.43	1395	16.89	-	-	-	-	
11000	1085	13.28	1123	13.93	1153	14.49	1182	14.98	1212	15.41	1242	15.81	1271	16.17	1302	16.52	1332	16.88	-	-	-	-	-	-	-	-	-	-	
	High static 15 HP and drive												High static 15 HP and field supplied drive																

1. Blower performance includes gas heat exchangers and 2-inch filters. See the static resistance table for additional applications.
2. See the RPM selection table to determine the required motor sheave setting and to determine the maximum continuous BHP.
3. kW = BHP x 0.813.

ZT180-276 bottom duct application

ZT180 (15 ton) bottom duct

Air flow (CFM)	Available external static pressure - IWG ¹																									
	0.4		0.6		0.8		1		1.2		1.4		1.6		1.8		2		2.2		2.4		2.6			
	RPM	BHP	RPM	BHP	RPM	BHP	RPM	BHP	RPM	BHP	RPM	BHP	RPM	BHP	RPM	BHP	RPM	BHP	RPM	BHP	RPM	BHP	RPM	BHP	RPM	BHP
	Standard 5 HP and field supplied drive								Standard 5 HP and drive								High static 7.5 HP and drive									
4000	636	0.61	675	0.95	714	1.27	752	1.58	789	1.87	825	2.16	861	2.43	896	2.69	930	2.94	963	3.18	996	3.42	1029	3.65		
4400	658	0.93	698	1.27	737	1.60	775	1.90	812	2.20	848	2.48	884	2.75	918	3.01	952	3.26	986	3.50	1019	3.74	1051	3.97		
4800	683	1.33	722	1.66	761	1.99	799	2.29	836	2.59	872	2.87	908	3.14	943	3.40	977	3.65	1010	3.90	1043	4.13	1076	4.36		
5200	709	1.78	749	2.11	788	2.44	825	2.74	863	3.04	899	3.32	934	3.59	969	3.85	1003	4.10	1037	4.35	1070	4.58	1102	4.82		
5600	737	2.28	777	2.62	816	2.94	854	3.25	891	3.55	927	3.83	963	4.10	997	4.36	1032	4.61	1065	4.85	1098	5.09	1130	5.32		
6000	768	2.84	807	3.18	846	3.50	884	3.81	921	4.10	957	4.39	993	4.66	1028	4.92	1062	5.17	1095	5.41	1128	5.65	1161	5.88		
6400	800	3.45	840	3.79	879	4.11	916	4.42	954	4.71	990	4.99	1025	5.26	1060	5.52	1094	5.77	1128	6.02	1161	6.25	1193	6.49		
6800	834	4.10	874	4.44	913	4.76	951	5.07	988	5.36	1024	5.64	1060	5.91	1094	6.17	1128	6.42	1162	6.67	1195	6.90	1227	7.14		
7200	870	4.79	910	5.13	949	5.45	987	5.76	1024	6.05	1060	6.33	1096	6.60	1131	6.86	1165	7.11	1198	7.36	1231	7.60	1264	7.83		
7600	908	5.52	948	5.86	987	6.18	1025	6.49	1062	6.78	1098	7.06	1134	7.33	1169	7.59	1203	7.84	1236	8.09	1269	8.33	-	-		
	High static 7.5 HP and field supplied drive																									

1. Blower performance includes gas heat exchangers and 2-inch filters. See the static resistance table for additional applications.
2. See the RPM selection table to determine the required motor sheave setting and to determine the maximum continuous BHP.
3. kW = BHP x 0.833.

ZT210 (17.5 ton) bottom duct

Air flow (CFM)	Available external static pressure - IWG ¹																									
	0.4		0.6		0.8		1		1.2		1.4		1.6		1.8		2		2.2		2.4		2.6			
	RPM	BHP	RPM	BHP	RPM	BHP	RPM	BHP	RPM	BHP	RPM	BHP	RPM	BHP	RPM	BHP	RPM	BHP	RPM	BHP	RPM	BHP	RPM	BHP	RPM	BHP
	Standard static 7.5 HP and field supplied drive										Standard 7.5 HP and drive															
4400	641	0.87	677	1.24	712	1.58	746	1.89	780	2.19	813	2.47	846	2.76	879	3.05	912	3.35	944	3.67	978	4.02	1011	4.40		
4800	660	1.18	696	1.56	731	1.89	765	2.21	799	2.50	832	2.79	865	3.07	898	3.36	931	3.66	964	3.98	997	4.33	1031	4.72		
5200	681	1.56	717	1.93	752	2.27	787	2.58	821	2.88	854	3.16	887	3.45	920	3.73	952	4.04	985	4.36	1018	4.71	1052	5.09		
5600	705	1.99	741	2.36	776	2.70	810	3.02	844	3.31	877	3.60	910	3.88	943	4.17	976	4.47	1009	4.79	1042	5.14	1075	5.53		
6000	730	2.49	766	2.86	801	3.20	836	3.52	869	3.81	903	4.10	936	4.38	968	4.67	1001	4.97	1034	5.29	1067	5.64	1101	6.03		
6400	757	3.06	793	3.43	828	3.77	863	4.08	897	4.38	930	4.66	963	4.94	996	5.23	1028	5.53	1061	5.86	1094	6.21	1128	6.59		
6800	786	3.68	822	4.05	857	4.39	892	4.71	925	5.00	959	5.29	992	5.57	1025	5.86	1057	6.16	1090	6.48	1123	6.83	1157	7.22		
7200	817	4.37	853	4.74	888	5.08	922	5.40	956	5.69	989	5.98	1022	6.26	1055	6.55	1088	6.85	1121	7.17	1154	7.52	1188	7.91		
7600	849	5.12	885	5.49	920	5.83	955	6.15	988	6.44	1022	6.73	1055	7.01	1087	7.30	1120	7.60	1153	7.92	1186	8.27	1220	8.66		
8000	883	5.93	919	6.30	954	6.64	989	6.95	1022	7.25	1056	7.54	1088	7.82	1121	8.11	1154	8.41	1187	8.73	1220	9.08	1254	9.47		
8400	918	6.80	954	7.17	989	7.51	1024	7.82	1058	8.12	1091	8.40	1124	8.69	1157	8.98	1189	9.28	1222	9.60	1255	9.95	1289	10.33		
8800	955	7.72	991	8.09	1026	8.43	1060	8.74	1094	9.04	1127	9.33	1160	9.61	1193	9.90	1226	10.20	1259	10.52	1292	10.87	1326	11.25		
	High static 10 HP and drive										High static 10 HP and field supplied drive															

1. Blower performance includes gas heat exchangers and 2-inch filters. See the static resistance table for additional applications.
2. See the RPM selection table to determine the required motor sheave setting and to determine the maximum continuous BHP.
3. kW = BHP x 0.813.

ZT240 (20 ton) bottom duct

Air flow (CFM)	Available external static pressure - IWG ¹																									
	0.4		0.6		0.8		1		1.2		1.4		1.6		1.8		2		2.2		2.4		2.6			
	RPM	BHP	RPM	BHP	RPM	BHP	RPM	BHP	RPM	BHP	RPM	BHP	RPM	BHP	RPM	BHP	RPM	BHP	RPM	BHP	RPM	BHP	RPM	BHP	RPM	BHP
	Standard static 7.5 HP and field supplied drive										Standard 7.5 HP and drive															
5200	681	1.56	717	1.93	752	2.27	787	2.58	821	2.88	854	3.16	887	3.45	920	3.73	952	4.04	985	4.36	1018	4.71	1052	5.09		
5600	705	1.99	741	2.36	776	2.70	810	3.02	844	3.31	877	3.60	910	3.88	943	4.17	976	4.47	1009	4.79	1042	5.14	1075	5.53		
6000	730	2.49	766	2.86	801	3.20	836	3.52	869	3.81	903	4.10	936	4.38	968	4.67	1001	4.97	1034	5.29	1067	5.64	1101	6.03		
6400	757	3.06	793	3.43	828	3.77	863	4.08	897	4.38	930	4.66	963	4.94	996	5.23	1028	5.53	1061	5.86	1094	6.21	1128	6.59		
6800	786	3.68	822	4.05	857	4.39	892	4.71	925	5.00	959	5.29	992	5.57	1025	5.86	1057	6.16	1090	6.48	1123	6.83	1157	7.22		
7200	817	4.37	853	4.74	888	5.08	922	5.40	956	5.69	989	5.98	1022	6.26	1055	6.55	1088	6.85	1121	7.17	1154	7.52	1188	7.91		
7600	849	5.12	885	5.49	920	5.83	955	6.15	988	6.44	1022	6.73	1055	7.01	1087	7.30	1120	7.60	1153	7.92	1186	8.27	1220	8.66		
8000	883	5.93	919	6.30	954	6.64	989	6.95	1022	7.25	1056	7.54	1088	7.82	1121	8.11	1154	8.41	1187	8.73	1220	9.08	1254	9.47		
8400	918	6.80	954	7.17	989	7.51	1024	7.82	1058	8.12	1091	8.40	1124	8.69	1157	8.98	1189	9.28	1222	9.60	1255	9.95	1289	10.33		
8800	955	7.72	991	8.09	1026	8.43	1060	8.74	1094	9.04	1127	9.33	1160	9.61	1193	9.90	1226	10.20	1259	10.52	1292	10.87	1326	11.25		
9200	993	8.70	1029	9.07	1064	9.41	1098	9.72	1132	10.02	1166	10.30	1198	10.59	1231	10.87	1264	11.18	1297	11.50	-	-	-	-		
9600	1032	9.73	1068	10.10	1103	10.44	1138	10.75	1172	11.05	1205	11.33	-	-	-	-	-	-	-	-	-	-	-	-		
	High static 10 HP and field supplied drive																									

1. Blower performance includes gas heat exchangers and 2-inch filters. See the static resistance table for additional applications.
2. See the RPM selection table to determine the required motor sheave setting and to determine the maximum continuous BHP.
3. kW = BHP x 0.813.

ZT276 (23 ton) bottom duct

Air flow (CFM)	Available external static pressure - IWG ¹																											
	0.4		0.6		0.8		1		1.2		1.4		1.6		1.8		2		2.2		2.4		2.6		2.8		3	
	RPM	BHP	RPM	BHP	RPM	BHP	RPM	BHP	RPM	BHP	RPM	BHP	RPM	BHP	RPM	BHP	RPM	BHP	RPM	BHP	RPM	BHP	RPM	BHP	RPM	BHP	RPM	BHP
	Low static 7.5 HP and field supplied drive						Low static 7.5 HP and drive						Standard static 10 HP and drive															
6600	777	2.64	808	3.13	840	3.59	888	4.01	902	4.41	934	4.79	965	5.15	997	5.50	1028	5.84	1060	6.19	1092	6.53	1123	6.89	1155	7.26	1187	7.66
7000	800	3.31	832	3.80	863	4.26	894	4.69	925	5.08	957	5.46	988	5.82	1020	6.17	1051	6.52	1083	6.86	1115	7.21	1146	7.57	1178	7.94	1210	8.33
7400	825	4.05	856	4.54	887	5.00	919	5.42	950	5.82	981	6.20	1013	6.56	1044	6.91	1076	7.25	1108	7.59	1139	7.94	1171	8.30	1203	8.67	1235	9.07
7800	851	4.84	885	5.33	914	5.79	945	6.22	976	6.62	1008	6.99	1039	7.35	1071	7.70	1102	8.05	1134	8.39	1166	8.74	1197	9.10	1229	9.47	1261	9.86
8200	884	5.70	910	6.19	942	6.65	973	7.07	1004	7.47	1036	7.85	1067	8.21	1098	8.56	1130	8.90	1162	9.25	1193	9.59	1225	9.95	1257	10.32	1289	10.72
8600	909	6.61	940	7.10	971	7.56	1002	7.98	1033	8.38	1065	8.76	1096	9.12	1128	9.47	1159	9.82	1191	10.16	1223	10.51	1255	10.86	1286	11.24	1318	11.63
9000	939	7.58	971	8.07	1002	8.53	1033	8.95	1064	9.35	1096	9.73	1127	10.09	1159	10.44	1190	10.78	1222	11.13	1254	11.48	1285	11.83	1317	12.21	1349	12.60
9400	972	8.60	1003	9.10	1034	9.55	1065	9.98	1097	10.38	1128	10.75	1159	11.12	1191	11.46	1223	11.81	1254	12.15	1286	12.50	1318	12.86	1350	13.23	1382	13.62
9800	1005	9.68	1037	10.17	1068	10.63	1099	11.06	1130	11.45	1162	11.83	1193	12.19	1225	12.54	1256	12.89	1288	13.23	1320	13.58	1351	13.94	1383	14.31	1415	14.70
10200	1041	10.81	1072	11.30	1103	11.76	1134	12.18	1165	12.58	1197	12.96	1228	13.32	1260	13.67	1291	14.02	1323	14.36	1355	14.71	1387	15.06	1418	15.44	1450	15.83
10600	1107	11.99	1108	12.48	1139	12.94	1171	13.36	1202	13.76	1233	14.14	1265	14.50	1296	14.85	1328	15.19	1360	15.54	1391	15.89	1423	16.24	-	-	-	-
11000	1115	13.22	1146	13.71	1177	14.17	1208	14.59	1240	14.99	1271	15.37	1303	15.73	1334	16.08	1366	16.42	-	-	-	-	-	-	-	-	-	-
	High static 15 HP and drive												High static 15 HP and field supplied drive															

RPM Selection

Size (tons)	Model	HP	Max BHP	Motor sheave	Blower sheave	6 turns open	5 turns open	4 turns open	3 turns open	2 turns open	1 turns open	Fully closed
180 (15)	ZT	5.0	5.75	1VP60	BK120	721	752	783	814	844	875	N/A
		7.5	8.63	1VP60	BK100	885	923	960	998	1036	1073	N/A
210 (17.5)	ZT	7.5	8.63	1VP60	BK110	800	834	868	902	936	970	N/A
		10.0	11.5	1VP60	BK90	979	1021	1063	1104	1146	1188	N/A
240 (20)	ZT	7.5	8.63	1VP60	BK110	800	834	868	902	936	970	N/A
		10.0	11.5	1VP60	BK90	979	1021	1063	1104	1146	1188	N/A
276 (23)	ZT	7.5	8.63	1VP60	1B5V94	885	923	960	998	1036	1073	N/A
		10.0	11.5	1VP75X	1B5V110	986	1018	1050	1082	1114	1145	1177
		15.0	17.25	1VP75X	1B5V94	1154	1191	1229	1266	1303	1340	1378

Additional static resistance

Size (tons)	Model	CFM	Cooling only ¹	Reheat coil ²	Economizer ^{2 3}	Electric heat kW ²			
						18	36	54	72
180 (15) 210 (17.5) 240 (20) 276 (23)	ZT	4500	0.25	0.15	0.10	0.10	0.20	0.20	0.20
		6000	0.35	0.20	0.10	0.20	0.30	0.30	0.40
		7500	0.45	0.25	0.10	0.20	0.30	0.40	0.40
		9000	0.50	0.30	0.15	0.50	0.50	0.70	0.80
		10500	0.55	0.40	0.15	0.70	0.80	0.90	0.90
		11000	0.60	0.45	0.20	0.80	0.90	1.00	1.00

1. Add these values to the available static resistance in the respective Blower Performance Tables.
2. Deduct these values from the available external static pressure shown in the respective Blower Performance Tables.
3. The pressure drop through the economizer is greater for 100% outdoor air than for 100% return air. If the resistance of the return air duct is less than 0.25 IWG, the unit will deliver less CFM during full economizer operation.

Drive selection

1. Determine side or bottom supply duct application.
2. Determine desired airflow
3. Calculate or measure the amount of external static pressure.
4. Using the operating point determined from steps 1, 2 & 3, locate this point on the appropriate supply air blower performance table. (Linear interpolation may be necessary.)
5. Noting the RPM and BHP from step 4, locate the appropriate motor and/or drive on the RPM selection table.
6. Review the BHP compared to the motor options available. Select the appropriate motor and/or drive.
7. Review the RPM range for the motor options available. Select the appropriate drive if multiple drives are available for the chosen motor.
8. Determine turns open to obtain the desired operation point.

Example

1. 6800 CFM
2. 2.0 iwg
3. Using the supply air blower performance table below, the following data point was located: 1020 RPM & 5.92 BHP.
4. Using the RPM selection table below, Size X and Model Y is found.
5. 5.92 BHP exceeds the maximum continuous BHP rating of the 5.0 HP motor. The 7.5 HP motor is required.
6. 1020 RPM is within the range of the 7.5 HP drives.
7. Using the 7.5 HP motor and drive, 3.5 turns open will achieve 1020 RPM.

Example supply air blower performance

Air flow (CFM)	Available external static pressure - IWG																							
	0.4		0.6		0.8		1.0		1.2		1.4		1.6		1.8		2.0		2.2		2.4		2.6	
	RPM	BHP	RPM	BHP	RPM	BHP	RPM	BHP	RPM	BHP	RPM	BHP	RPM	BHP	RPM	BHP	RPM	BHP	RPM	BHP	RPM	BHP	RPM	BHP
	Standard 5 HP and field supplied drive		Standard 5 HP and drive										High static 7.5 HP and drive											
6400	719	2.55	756	3.03	792	3.49	828	3.92	864	4.32	899	4.67	933	4.98	966	5.24	998	5.45	1028	5.59	1056	5.67	1083	5.68
6800	742	3.02	778	3.51	814	3.97	850	4.40	886	4.79	921	5.15	955	5.46	988	5.72	1020	5.92	1050	6.07	1078	6.15	1105	6.16
7200	765	3.54	802	4.03	838	4.49	874	4.92	910	5.32	945	5.67	979	5.98	1012	6.24	1044	6.44	1074	6.59	1102	6.67	1129	6.68
7600	790	4.11	827	4.60	863	5.06	899	5.49	935	5.88	970	6.24	1004	6.55	1037	6.81	1069	7.01	1099	7.16	1127	7.24	1154	7.25
																								7.5 HP and field supplied drive

Table X: RPM selection

Size (tons)	Model	HP	Max BHP	Motor sheave	Blower sheave	6 turns open	5 turns open	4 turns open	3 turns open	2 turns open	1 turn open	Fully closed
X	Y	5	5.75	1VP60	BK110	730	765	800	835	870	905	N/A
		7.5	8.63	1VP60	BK090	905	950	990	1035	1075	1120	N/A

Altitude/temperature correction factors

Air temp.	Altitude (Ft.)										
	0	1000	2000	3000	4000	5000	6000	7000	8000	9000	10000
40	1.060	1.022	0.986	0.950	0.916	0.882	0.849	0.818	0.788	0.758	0.729
50	1.039	1.002	0.966	0.931	0.898	0.864	0.832	0.802	0.772	0.743	0.715
60	1.019	0.982	0.948	0.913	0.880	0.848	0.816	0.787	0.757	0.729	0.701
70	1.000	0.964	0.930	0.896	0.864	0.832	0.801	0.772	0.743	0.715	0.688
80	0.982	0.947	0.913	0.880	0.848	0.817	0.787	0.758	0.730	0.702	0.676
90	0.964	0.929	0.897	0.864	0.833	0.802	0.772	0.744	0.716	0.689	0.663
100	0.946	0.912	0.880	0.848	0.817	0.787	0.758	0.730	0.703	0.676	0.651

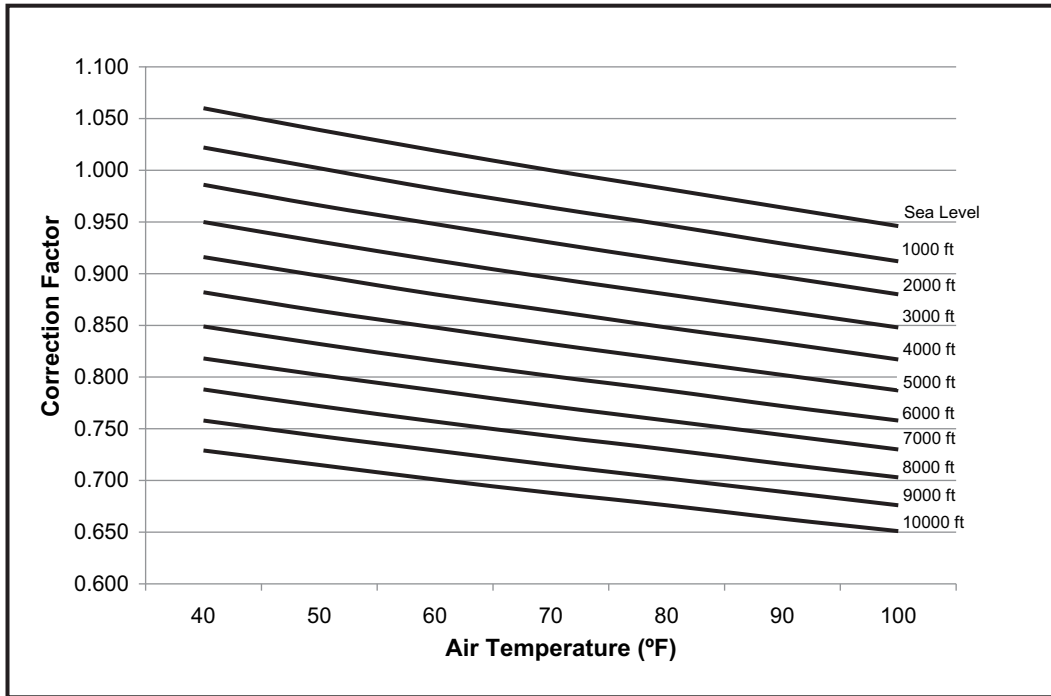

Gas heat minimum supply air

Size (tons)	Heat size	Supply air (CFM)			
		Cooling		Heating	
		Min	Max	Min	Max
180 (15)	N30	4500	7000	4500	7000
	N40	4500	7000	5000	7000
210 (17.5)	N30	6000	8750	6000	8750
	N40	6000	8750	6000	8750
240 (20)	N30	6000	9400	6000	9400
	N40	6000	9400	6000	9400
276 (23)	N30	7500	12500	7500	12500
	N40	7500	12500	7500	12500

⚠ CAUTION

For units with VFD and gas heat, the speed of the indoor blower motor continues to be controlled by duct static pressure via the VAV control board.

If there are VAV boxes present in the duct system, the boxes must be driven to the full-open position using a customer-supplied power source to assure adequate airflow across electric heating elements or gas heat exchanger tubes.

Electric heat minimum supply air

Size (tons)	Voltage	Minimum supply air (CFM)			
		Heater kW			
		18	36	54	72
180 (15)	208/230-3-60	4500	4500	5000	5000
	460-3-60	4500	4500	5000	4500
210 (17.5)	208/230-3-60	6000	6000	6000	6000
	460-3-60	6000	6000	6000	6000
240 (20)	208/230-3-60	6000	6000	6000	6000
	460-3-60	6000	6000	6000	6000
276 (23)	208/230-3-60	7500	7500	7500	7500
	460-3-60	7500	7500	7500	7500



For units with VFD and electric heat, the speed of the indoor blower motor continues to be controlled by duct static pressure via the VAV control board.

If there are VAV boxes present in the duct system, the boxes must be driven to the full-open position using a customer-supplied power source to assure adequate airflow across electric heating elements or gas heat exchanger tubes.

Indoor blower specifications

Size (tons)	Model	Motor					Motor sheave			Blower sheave			Belt
		HP	RPM	Eff.	SF	Frame	Datum dia. (in.)	Bore (in.)	Model	Datum dia. (in.)	Bore (in.)	Model	
180 (15)	ZT	5.0	1725	0.89	1.15	184T	4.3 - 5.5	1 1/8	1VP60	11.4	1 3/16	BK120	BX81
		7.5	1725	0.91	1.15	213T	4.3 - 5.5	1 3/8	1VP60	9.4	1 3/16	BK100	BX75
210 (17.5)	ZT	7.5	1725	0.91	1.15	213T	4.3 - 5.5	1 3/8	1VP60	10.4	1 3/16	BK110	BX78
		10.0	1725	0.91	1.15	215T	4.3 - 5.5	1 3/8	1VP60	8.4	1 3/16	BK090	BX75
240 (20)	ZT	7.5	1725	0.91	1.15	213T	4.3 - 5.5	1 3/8	1VP60	10.4	1 3/16	BK110	BX78
		10.0	1725	0.91	1.15	215T	4.3 - 5.5	1 3/8	1VP60	8.4	1 3/16	BK090	BX75
276 (23)	ZT	7.5	1725	0.91	1.15	213T	4.3 - 5.5	1 3/8	1VP60	9.4	1 7/16	1B5V94	BX78
		10.0	1725	0.91	1.15	215T	5.8 - 7.0	1 3/8	1VP75X	11.1	1 7/16	1B5V110	5VX840
		15.0	1725	0.93	1.15	254T	6.2 - 7.4	1 5/8	1VP75X	9.5	1 7/16	1B5V94	5VX840

Power exhaust specifications

Voltage	Motor			Motor			CFM @ 0.2 ESP
	HP	RPM ¹	QTY	LRA	FLA	MCA	
208/230-1-60	3/4	1075	1	7.7	5.0	6.25	5250
460-1-60	3/4	1075	1	4.1	2.2	2.75	5250

1. Motors are multi-tapped and factory wired for high speed.

Electric heat multipliers

Voltage		kW capacity multipliers ¹
Nominal	Applied	
240	208	0.75
	230	0.92
480	460	0.92

1. Electric heaters are rated at nominal voltage. Use this table to determine the electric heat capacity for heaters applied at lower voltages.

Sound Performance

ZT Outdoor sound power levels

Size (tons)	Sound rating ¹ dB (A)	Sound power, dB (10^{-12}) Watts							
		Octave band center frequency (Hz)							
		63	125	250	500	1000	2000	4000	8000
180 (15)	79	82	81	77	75	75	69	64	61
210 (17.5)	85	89	87	86	83	80	76	70	65
240 (20)	87	87	88	86	85	82	78	73	68
276 (23)	89	99	97	92	87	82	77	72	69

1. Rated in accordance with standard AHRI 370-2015.

Electrical data

ZT180-276 - standard drive without powered convenience outlet

Size (tons)	Volt	Compressors (each)									OD fan motors (each) FLA	Supply blower motor FLA	Pwr conv outlet FLA	Electric heat				MCA ¹ (amps)	Max fuse ² / breaker ³ size (amps)
		RLA			LRA			MCC						Model	kW	Stages	Amps		
		C1	C2	C3	C1	C2	C3	C1	C2	C3									
180 (15)	208-3-60	25.3	25.3		184	184		40	40		3.5	13.5		None	-	-	-	84.4	100
														E18	13.5	1	37.5	84.4	100
														E36	27	2	74.9	110.5	125
														E54	40.6	2	112.7	157.8	175
														E72	54.1	2	150.2	167.1	200
	230-3-60	25.3	25.3		184	184		40	40		3.5	13		None	-	-	-	83.9	100
														E18	18	1	43.3	83.9	100
														E36	36	2	86.6	124.5	125
														E54	54	2	129.9	146.2	175
														E72	72	2	173.2	189.5	225
	460-3-60	9.6	9.6		84	84	15	15	15		1.6	6.5		None	-	-	-	34.5	40
														E18	18	1	21.7	35.3	40
														E36	36	2	43.3	62.3	70
														E54	54	2	65	73.1	80
														E72	72	2	86.6	94.7	110
210 (17.5)	208-3-60	26.9	28.8		164	223		42	45		5.3	20		None	-	-	-	104.1	125
														E118	13.5	1	37.5	104.1	125
														E136	27	2	74.9	118.6	125
														E154	40.6	2	112.7	165.9	175
														E172	54.1	2	150.2	175.2	200
	230-3-60	26.9	28.8		164	223		42	45		5.3	19.4		None	-	-	-	103.5	125
														E118	18	1	43.3	103.5	125
														E136	36	2	86.6	132.5	150
														E154	54	2	129.9	154.2	175
														E172	72	2	173.2	197.5	225
	460-3-60	12	12.5		94	100	15	19	20		2.5	9.7		None	-	-	-	47.3	50
														E18	18	1	21.7	47.3	50
														E36	36	2	43.3	66.3	70
														E54	54	2	65	77.1	90
														E72	72	2	86.6	98.7	110
240 (20)	208-3-60	32.6	16	23.2	240	110	164	51	25	36	5.3	20		None	-	-	-	121.2	150
														E118	13.5	1	37.5	121.2	150
														E136	27	2	74.9	121.2	150
														E154	40.6	2	112.7	165.9	175
														E172	54.1	2	150.2	175.2	200
	230-3-60	32.6	16	23.2	240	110	164	51	25	36	5.3	19.4		None	-	-	-	120.6	150
														E118	18	1	43.3	120.6	150
														E136	36	2	86.6	132.5	150
														E154	54	2	129.9	154.2	175
														E172	72	2	173.2	197.5	225
	460-3-60	14.8	7.8	11.2	130	52	75	23	12	18	2.5	9.7		None	-	-	-	57.2	70
														E18	18	1	21.7	57.2	70
														E36	36	2	43.3	66.3	70
														E54	54	2	65	77.1	90
														E72	72	2	86.6	98.7	110
276 (23)	208-3-60	35.4	15.6	25	240	110	164	55	24	39	5.3	26		None	-	-	-	132.1	150
														E118	13.5	1	37.5	132.1	150
														E136	27	2	74.9	132.1	150
														E154	40.6	2	112.7	173.4	175
														E172	54.1	2	150.2	182.7	200
	230-3-60	35.4	15.6	25	240	110	164	55	24	39	5.3	25		None	-	-	-	131.1	150
														E118	18	1	43.3	131.1	150
														E136	36	2	86.6	139.5	150
														E154	54	2	129.9	161.2	175
														E172	72	2	173.2	204.5	225
	460-3-60	16.5	7.8	12.2	140	52	100	26	12	19	2.5	12.5		None	-	-	-	63.1	70
														E18	18	1	21.7	63.1	70
														E36	36	2	43.3	69.8	70
														E54	54	2	65	80.6	90
														E72	72	2	86.6	102.2	110

1. Minimum Circuit Ampacity.

2. Dual Element, Time Delay Type.

3. HACR type per NEC.

ZT180-276 - standard drive with powered convenience outlet

Size (tons)	Volt	Compressors (each)									OD fan motors (each) FLA	Supply blower motor FLA	Pwr conv outlet FLA	Electric heat				MCA ¹ (amps)	Max fuse ^{2/} breaker ³ size (amps)
		RLA			LRA			MCC						Model	kW	Stages	Amps		
		C1	C2	C3	C1	C2	C3	C1	C2	C3									
180 (15)	208-3-60	25.3	25.3		184	184		40	40		3.5	13.5	20	None	-	-	-	94.4	110
														E18	13.5	1	37.5	94.4	110
														E36	27	2	74.9	123	125
														E54	40.6	2	112.7	170.3	175
	230-3-60	25.3	25.3		184	184		40	40		3.5	13	20	None	-	-	-	93.9	110
														E18	18	1	43.3	93.9	110
														E36	36	2	86.6	137	150
														E54	54	2	129.9	158.7	175
	460-3-60	9.6	9.6		84	84		15	15		1.6	6.5	20	None	-	-	-	39.5	45
														E18	18	1	21.7	41.5	45
														E36	36	2	43.3	68.5	70
														E54	54	2	65	79.4	90
210 (17.5)	208-3-60	26.9	28.8		164	223		42	45		5.3	20	20	None	-	-	-	114.1	125
														E118	13.5	1	37.5	114.1	125
														E136	27	2	74.9	131.1	150
														E154	40.6	2	112.7	178.4	200
														E172	54.1	2	150.2	187.7	200
	230-3-60	26.9	28.8		164	223		42	45		5.3	19.4	20	None	-	-	-	113.5	125
														E118	18	1	43.3	113.5	125
														E136	36	2	86.6	145	150
														E154	54	2	129.9	166.7	175
	460-3-60	12	12.5		94	100		19	20		2.5	9.7	20	None	-	-	-	52.3	60
														E18	18	1	21.7	52.3	60
														E36	36	2	43.3	72.5	80
E54														54	2	65	83.4	90	
240 (20)	208-3-60	32.6	16	23.2	240	110	164	51	25	36	5.3	20	20	None	-	-	-	131.2	150
														E118	13.5	1	37.5	131.2	150
														E136	27	2	74.9	131.2	150
														E154	40.6	2	112.7	178.4	200
														E172	54.1	2	150.2	187.7	200
	230-3-60	32.6	16	23.2	240	110	164	51	25	36	5.3	19.4	20	None	-	-	-	130.6	150
														E118	18	1	43.3	130.6	150
														E136	36	2	86.6	145	150
														E154	54	2	129.9	166.7	175
	460-3-60	14.8	7.8	11.2	130	52	75	23	12	18	2.5	9.7	20	None	-	-	-	62.2	70
														E18	18	1	21.7	62.2	70
														E36	36	2	43.3	72.5	80
E54														54	2	65	83.4	90	
276 (23)	208-3-60	35.4	15.6	25	240	110	164	55	24	39	5.3	26	20	None	-	-	-	142.1	175
														E118	13.5	1	37.5	142.1	175
														E136	27	2	74.9	142.1	175
														E154	40.6	2	112.7	185.9	200
														E172	54.1	2	150.2	195.2	200
	230-3-60	35.4	15.6	25	240	110	164	55	24	39	5.3	25	20	None	-	-	-	141.1	175
														E118	18	1	43.3	141.1	175
														E136	36	2	86.6	152	175
														E154	54	2	129.9	173.7	175
	460-3-60	16.5	7.8	12.2	140	52	100	26	12	19	2.5	12.5	20	None	-	-	-	68.1	80
														E18	18	1	21.7	68.1	80
														E36	36	2	43.3	76	80
E54														54	2	65	86.9	90	
													E72	72	2	86.6	108.5	110	

1. Minimum Circuit Ampacity.
2. Dual Element, Time Delay Type.
3. HACR type per NEC.

ZT180-276 - high static drive without powered convenience outlet

Size (tons)	Volt	Compressors (each)									OD fan motors (each) FLA	Supply blower motor FLA	Pwr conv outlet FLA	Electric heat				MCA ¹ (amps)	Max fuse ² / breaker ³ size (amps)
		RLA			LRA			MCC						Model	kW	Stages	Amps		
		C1	C2	C3	C1	C2	C3	C1	C2	C3									
180 (15)	208-3-60	25.3	25.3		184	184		40	40		3.5	20		None	-	-	-	90.9	110
														E18	13.5	1	37.5	90.9	110
														E36	27	2	74.9	118.6	125
														E54	40.6	2	112.7	165.9	175
														E72	54.1	2	150.2	175.2	200
	230-3-60	25.3	25.3		184	184		40	40		3.5	19.4		None	-	-	-	90.3	110
														E18	18	1	43.3	90.3	110
														E36	36	2	86.6	132.5	150
														E54	54	2	129.9	154.2	175
														E72	72	2	173.2	197.5	225
	460-3-60	9.6	9.6		84	84		15	15		1.6	9.7		None	-	-	-	37.7	45
														E18	18	1	21.7	39.3	45
E36														36	2	43.3	66.3	70	
E54														54	2	65	77.1	90	
E72														72	2	86.6	98.7	110	
210 (17.5)	208-3-60	26.9	28.8		164	223		42	45		5.3	26		None	-	-	-	110.1	125
														E118	13.5	1	37.5	110.1	125
														E136	27	2	74.9	126.1	150
														E154	40.6	2	112.7	173.4	175
														E172	54.1	2	150.2	182.7	200
	230-3-60	26.9	28.8		164	223		42	45		5.3	25		None	-	-	-	109.1	125
														E118	18	1	43.3	109.1	125
														E136	36	2	86.6	139.5	150
														E154	54	2	129.9	161.2	175
														E172	72	2	173.2	204.5	225
	460-3-60	12	12.5		94	100		19	20		2.5	12.5		None	-	-	-	50.1	60
														E18	18	1	21.7	50.1	60
E36														36	2	43.3	69.8	70	
E54														54	2	65	80.6	90	
E72														72	2	86.6	102.2	110	
240 (20)	208-3-60	32.6	16	23.2	240	110	164	51	25	36	5.3	26		None	-	-	-	127.2	150
														E118	13.5	1	37.5	127.2	150
														E136	27	2	74.9	127.2	150
														E154	40.6	2	112.7	173.4	175
														E172	54.1	2	150.2	182.7	200
	230-3-60	32.6	16	23.2	240	110	164	51	25	36	5.3	25		None	-	-	-	126.2	150
														E118	18	1	43.3	126.2	150
														E136	36	2	86.6	139.5	150
														E154	54	2	129.9	161.2	175
														E172	72	2	173.2	204.5	225
	460-3-60	14.8	7.8	11.2	130	52	75	23	12	18	2.5	12.5		None	-	-	-	60	70
														E18	18	1	21.7	60	70
E36														36	2	43.3	69.8	70	
E54														54	2	65	80.6	90	
E72														72	2	86.6	102.2	110	
276 (23)	208-3-60	35.4	15.6	25	240	110	164	55	24	39	5.3	37.2		None	-	-	-	143.7	175
														E118	13.5	1	37.5	143.7	175
														E136	27	2	74.9	143.7	175
														E154	40.6	2	112.7	187.4	200
														E172	54.1	2	150.2	196.7	225
	230-3-60	35.4	15.6	25	240	110	164	55	24	39	5.3	34.6		None	-	-	-	140.7	175
														E118	18	1	43.3	140.7	175
														E136	36	2	86.6	151.5	175
														E154	54	2	129.9	173.2	200
														E172	72	2	173.2	216.5	250
	460-3-60	16.5	7.8	12.2	140	52	100	26	12	19	2.5	17.3		None	-	-	-	68.1	80
														E18	18	1	21.7	68.1	80
E36														36	2	43.3	75.8	80	
E54														54	2	65	86.6	100	
E72														72	2	86.6	108.2	125	

1. Minimum Circuit Ampacity.
2. Dual Element, Time Delay Type.
3. HACR type per NEC.

ZT180-276 - high static drive with powered convenience outlet

Size (tons)	Volt	Compressors (each)									OD fan motors (each) FLA	Supply blower motor FLA	Pwr conv outlet FLA	Electric heat				MCA ¹ (amps)	Max fuse ^{2/} breaker ³ size (amps)
		RLA			LRA			MCC						Model	kW	Stages	Amps		
		C1	C2	C3	C1	C2	C3	C1	C2	C3									
180 (15)	208-3-60	25.3	25.3		184	184		40	40		3.5	20	20	None	-	-	-	100.9	125
														E18	13.5	1	37.5	100.9	125
														E36	27	2	74.9	131.1	150
														E54	40.6	2	112.7	178.4	200
														E72	54.1	2	150.2	187.7	200
	230-3-60	25.3	25.3		184	184		40	40		3.5	19.4	20	None	-	-	-	100.3	125
														E18	18	1	43.3	100.3	125
														E36	36	2	86.6	145	150
														E54	54	2	129.9	166.7	175
														E72	72	2	173.2	210	225
	460-3-60	9.6	9.6		84	84		15	15		1.6	9.7	20	None	-	-	-	42.7	50
														E18	18	1	21.7	45.5	50
														E36	36	2	43.3	72.5	80
														E54	54	2	65	83.4	90
														E72	72	2	86.6	105	110
210 (17.5)	208-3-60	26.9	28.8		164	223		42	45		5.3	26	20	None	-	-	-	120.1	125
														E118	13.5	1	37.5	120.1	125
														E136	27	2	74.9	138.6	150
														E154	40.6	2	112.7	185.9	200
														E172	54.1	2	150.2	195.2	200
	230-3-60	26.9	28.8		164	223		42	45		5.3	25	20	None	-	-	-	119.1	125
														E118	18	1	43.3	119.1	125
														E136	36	2	86.6	152	175
														E154	54	2	129.9	173.7	175
														E172	72	2	173.2	217	225
	460-3-60	12	12.5		94	100		19	20		2.5	12.5	20	None	-	-	-	55.1	60
														E18	18	1	21.7	55.1	60
														E36	36	2	43.3	76	80
														E54	54	2	65	86.9	90
														E72	72	2	86.6	108.5	110
240 (20)	208-3-60	32.6	16	23.2	240	110	164	51	25	36	5.3	26	20	None	-	-	-	137.2	150
														E118	13.5	1	37.5	137.2	150
														E136	27	2	74.9	138.6	150
														E154	40.6	2	112.7	185.9	200
														E172	54.1	2	150.2	195.2	200
	230-3-60	32.6	16	23.2	240	110	164	51	25	36	5.3	25	20	None	-	-	-	136.2	150
														E118	18	1	43.3	136.2	150
														E136	36	2	86.6	152	175
														E154	54	2	129.9	173.7	175
														E172	72	2	173.2	217	225
	460-3-60	14.8	7.8	11.2	130	52	75	23	12	18	2.5	12.5	20	None	-	-	-	65	70
														E18	18	1	21.7	65	70
														E36	36	2	43.3	76	80
														E54	54	2	65	86.9	90
														E72	72	2	86.6	108.5	110
276 (23)	208-3-60	35.4	15.6	25	240	110	164	55	24	39	5.3	37.2	20	None	-	-	-	153.7	175
														E118	13.5	1	37.5	153.7	175
														E136	27	2	74.9	153.7	175
														E154	40.6	2	112.7	199.9	200
														E172	54.1	2	150.2	209.2	225
	230-3-60	35.4	15.6	25	240	110	164	55	24	39	5.3	34.6	20	None	-	-	-	150.7	175
														E118	18	1	43.3	150.7	175
														E136	36	2	86.6	164	175
														E154	54	2	129.9	185.7	200
														E172	72	2	173.2	229	250
	460-3-60	16.5	7.8	12.2	140	52	100	26	12	19	2.5	17.3	20	None	-	-	-	73.1	90
														E18	18	1	21.7	73.1	90
														E36	36	2	43.3	82	90
														E54	54	2	65	92.9	100
														E72	72	2	86.6	114.5	125

1. Minimum Circuit Ampacity.
2. Dual Element, Time Delay Type.
3. HACR type per NEC.

ZT276 - low static drive without powered convenience outlet

Size (tons)	Volt	Compressors (each)									OD fan motors (each)	Supply blower motor	Pwr conv outlet	Electric heat				MCA ¹ (amps)	Max fuse ² / breaker ³ size (amps)			
		RLA			LRA			MCC						FLA	FLA	FLA	Model			kW	Stages	Amps
		C1	C2	C3	C1	C2	C3	C1	C2	C3												
276 (23)	208-3-60	35.4	15.6	25	240	110	164	55	24	39	5.3	20		None	-	-	-	126.1	150			
														E118	13.5	1	37.5	126.1	150			
														E136	27	2	74.9	126.1	150			
														E154	40.6	2	112.7	165.9	175			
	230-3-60	35.4	15.6	25	240	110	164	55	24	39	5.3	19.4		None	-	-	-	125.5	150			
														E118	18	1	43.3	125.5	150			
														E136	36	2	86.6	132.5	150			
														E154	54	2	129.9	154.2	175			
	460-3-60	16.5	7.8	12.2	140	52	100	26	12	19	2.5	9.7		None	-	-	-	60.3	70			
														E18	18	1	21.7	60.3	70			
														E36	36	2	43.3	66.3	70			
														E54	54	2	65	77.1	90			
													E72	72	2	86.6	98.7	110				

1. Minimum Circuit Ampacity.
2. Dual Element, Time Delay Type.
3. HACR type per NEC.

ZT276 - low static drive with powered convenience outlet

Size (tons)	Volt	Compressors (each)									OD fan motors (each)	Supply blower motor	Pwr conv outlet	Electric heat				MCA ¹ (amps)	Max fuse ² / breaker ³ size (amps)			
		RLA			LRA			MCC						FLA	FLA	FLA	Model			kW	Stages	Amps
		C1	C2	C3	C1	C2	C3	C1	C2	C3												
276 (23)	208-3-60	35.4	15.6	25	240	110	164	55	24	39	5.3	20	20	None	-	-	-	136.1	150			
														E118	13.5	1	37.5	136.1	150			
														E136	27	2	74.9	136.1	150			
														E154	40.6	2	112.7	178.4	200			
	230-3-60	35.4	15.6	25	240	110	164	55	24	39	5.3	19.4	20	None	-	-	-	135.5	150			
														E118	18	1	43.3	135.5	150			
														E136	36	2	86.6	145	150			
														E154	54	2	129.9	166.7	175			
	460-3-60	16.5	7.8	12.2	140	52	100	26	12	19	2.5	9.7	20	None	-	-	-	65.3	80			
														E18	18	1	21.7	65.3	80			
														E36	36	2	43.3	72.5	80			
														E54	54	2	65	83.4	90			
													E72	72	2	86.6	105	110				

1. Minimum Circuit Ampacity.
2. Dual Element, Time Delay Type.
3. HACR type per NEC.

ZT180-276 wiring diagrams

ZT180-276 typical control diagram

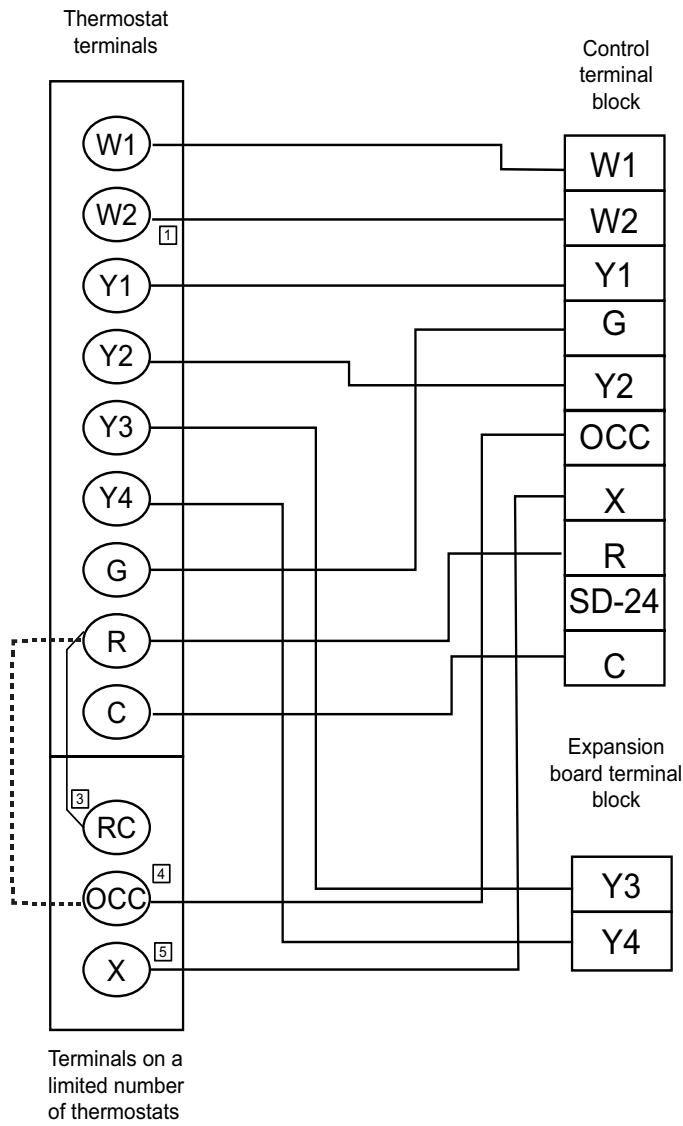

R~OCC jumper

Smart Equipment™ control boards come from the factory with a jumper wire between the R and OCC terminals on the thermostat terminal strip.

To enable thermostat or EMS control of the occupied mode for the unit, remove the jumper during commissioning.

If you do not remove the jumper, the unit remains in occupied mode regardless of the occupancy demand from the thermostat or EMS system.

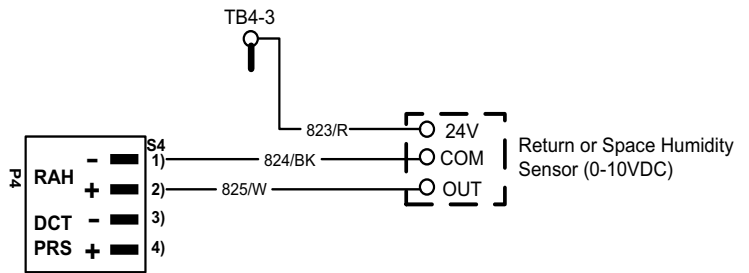
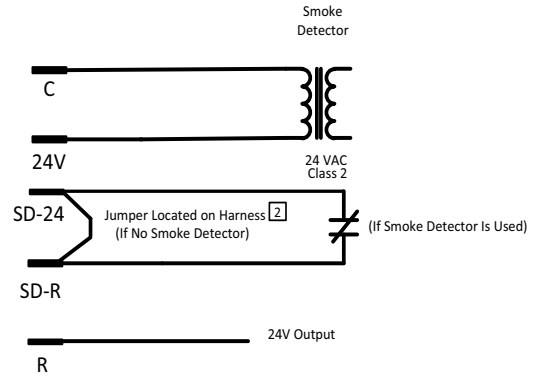

For units with optional reheat operation

- 1) Second stage heating not required on single stage heating units.
- 2) Jumper is required if there is no Smoke Detector circuit.
- 3) Jumper is required for any combination of R, RC, or RH.
- 4) OCC is an output from the thermostat to indicate the Occupied condition.
- 5) X is an input to the thermostat to display Error Status conditions.

15-17.5 ton - 3 stage cooling UHE unit with gas or electric heat

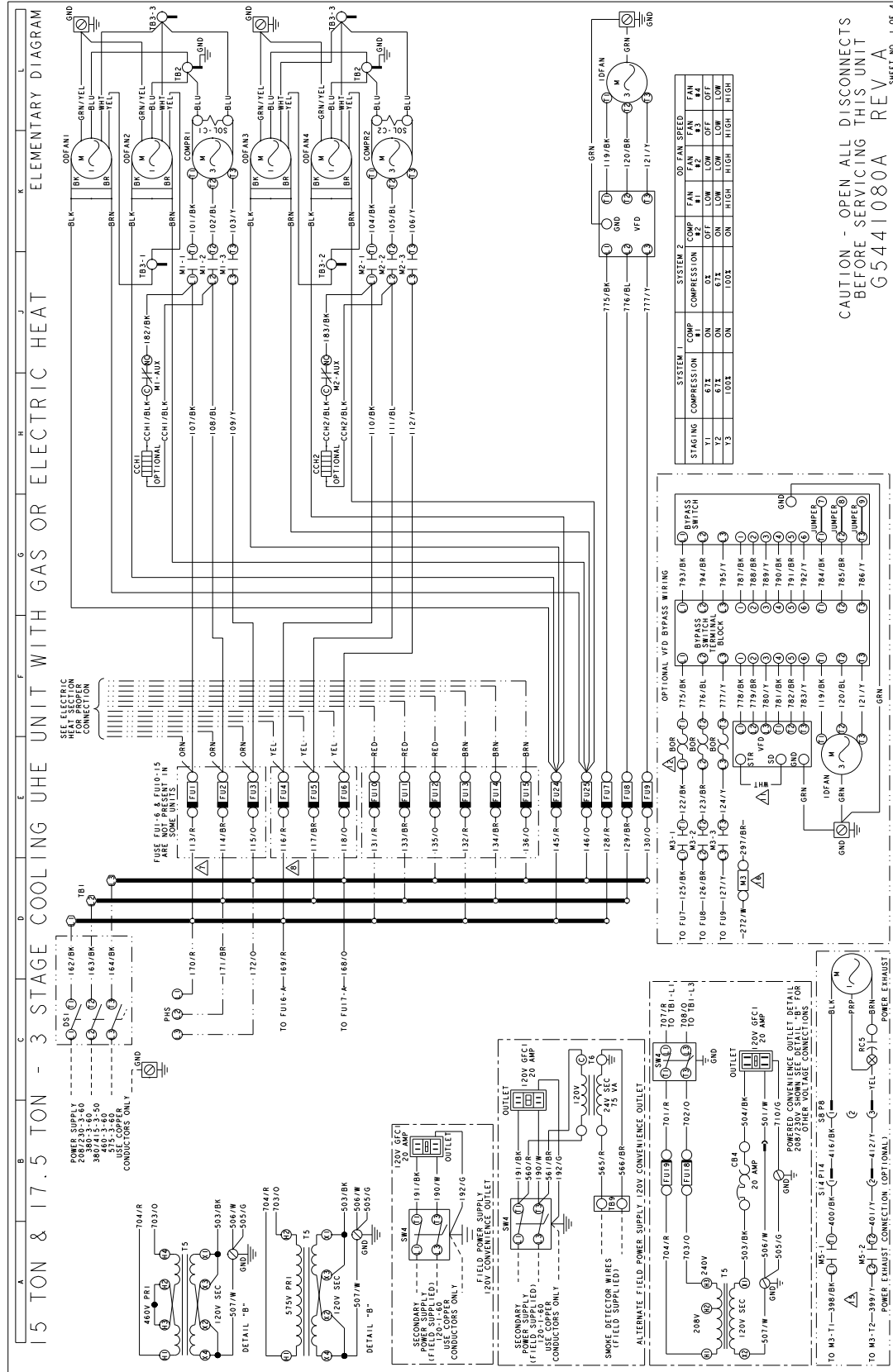

15-17.5 ton - 3 stage cooling UHE unit with gas or electric heat (continued)

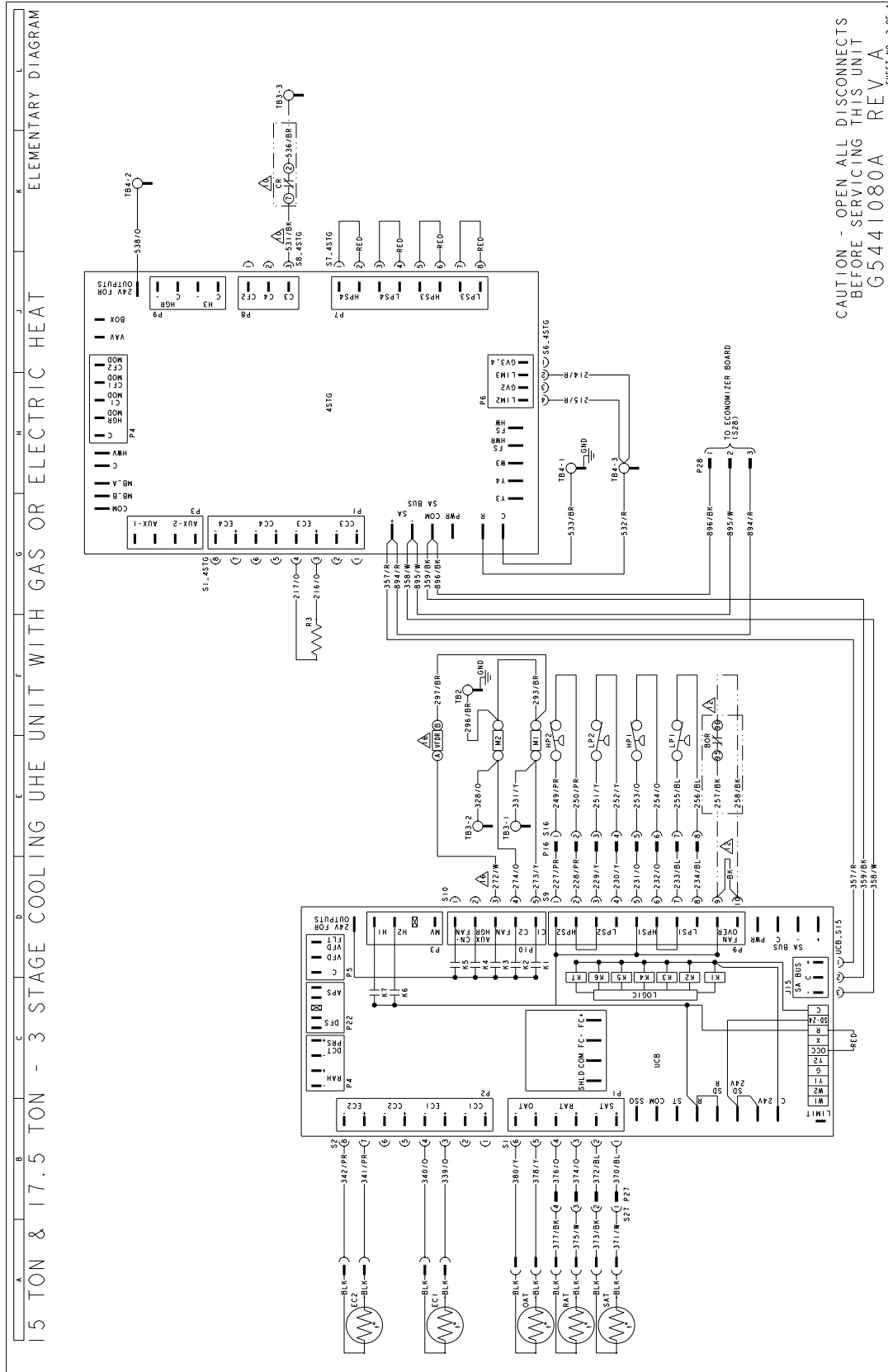

15-17.5 ton - 3 stage cooling UHE unit with gas or electric heat (continued)

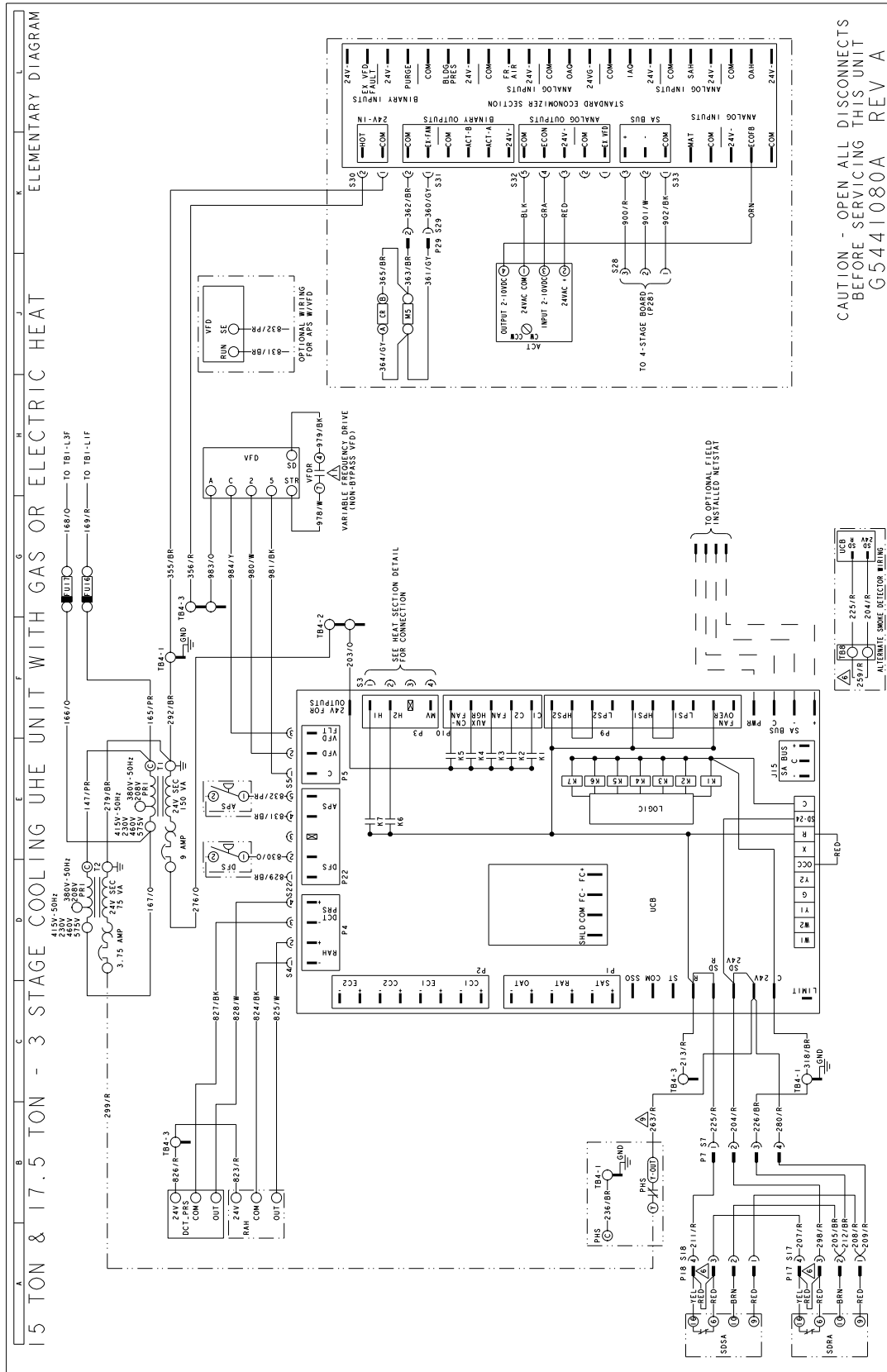

15-17.5 ton - 3 stage cooling UHE unit with gas or electric heat (continued)

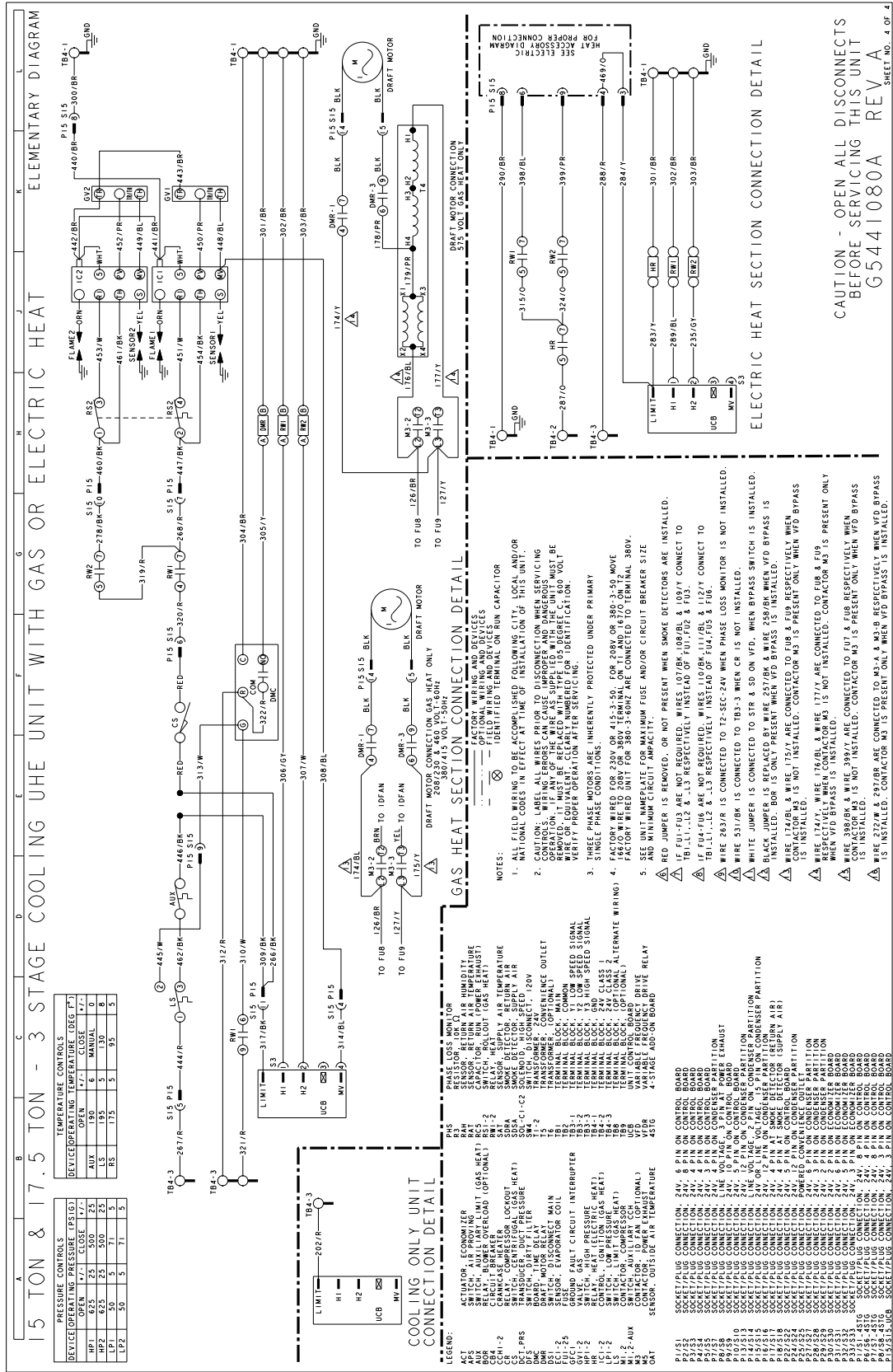

15-17.5 ton - 3 stage reheat UHE unit with gas or electric heat

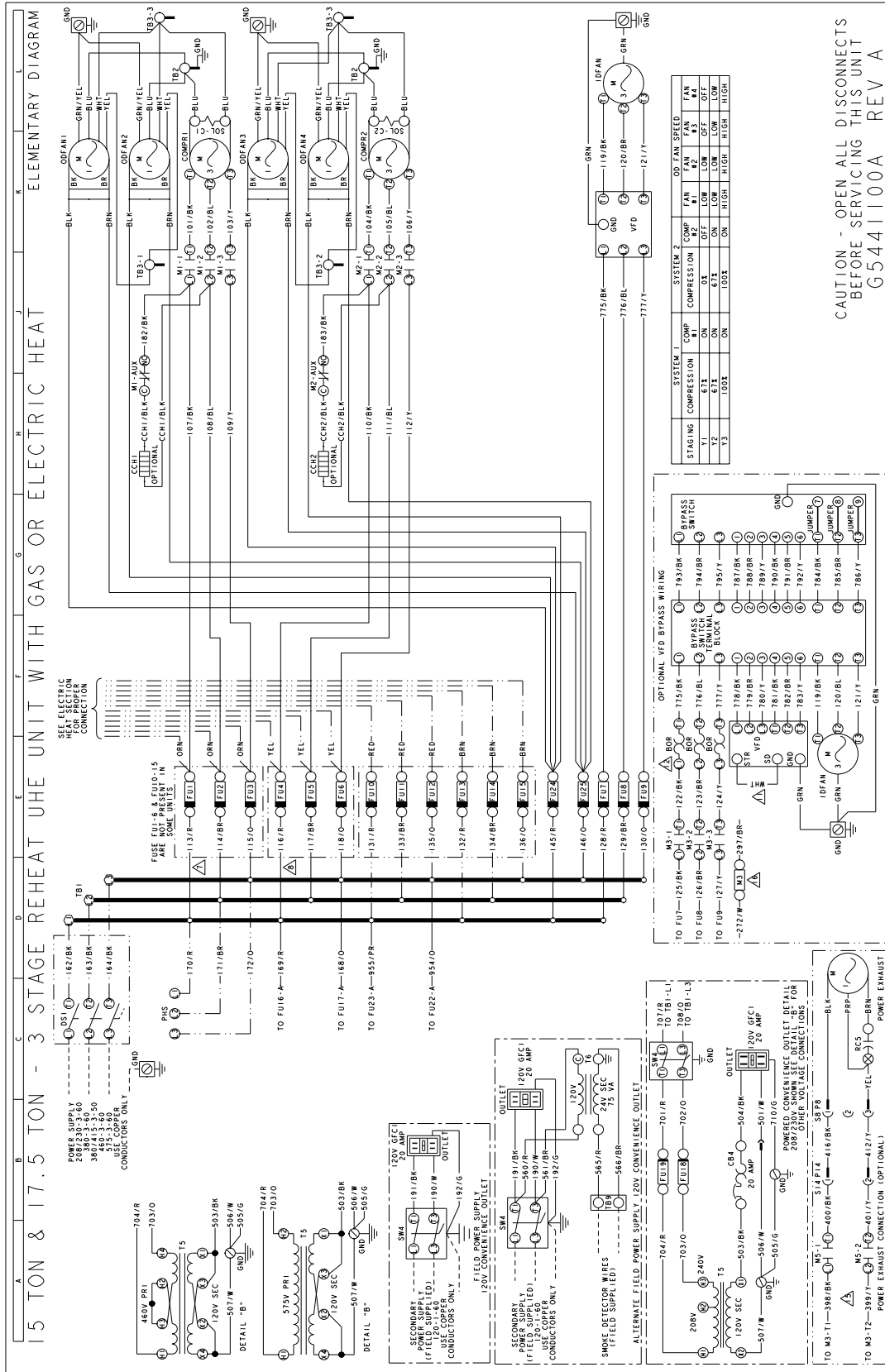

15-17.5 ton - 3 stage reheat UHE unit with gas or electric heat (continued)

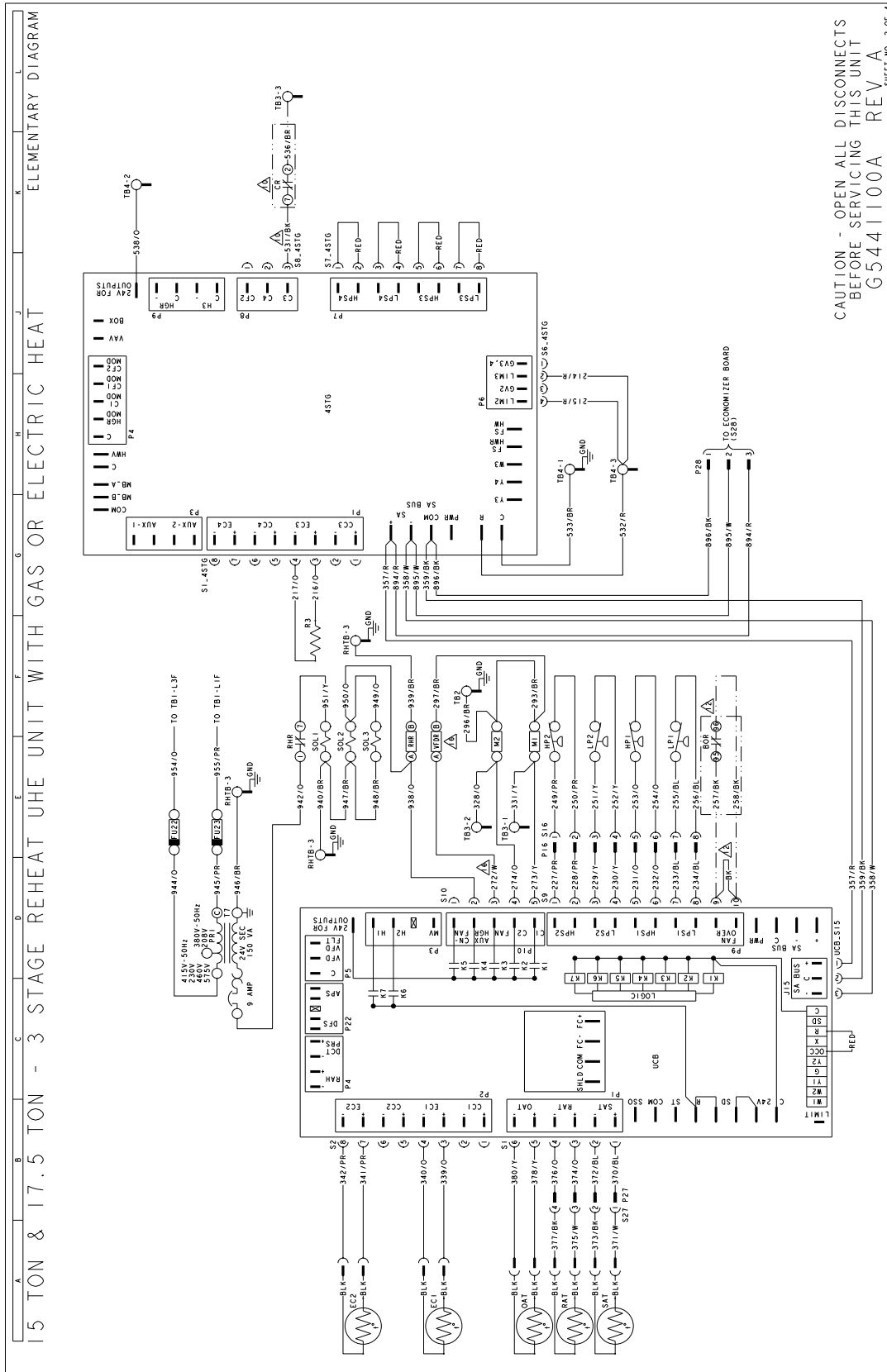

15-17.5 ton - 3 stage reheat UHE unit with gas or electric heat (continued)

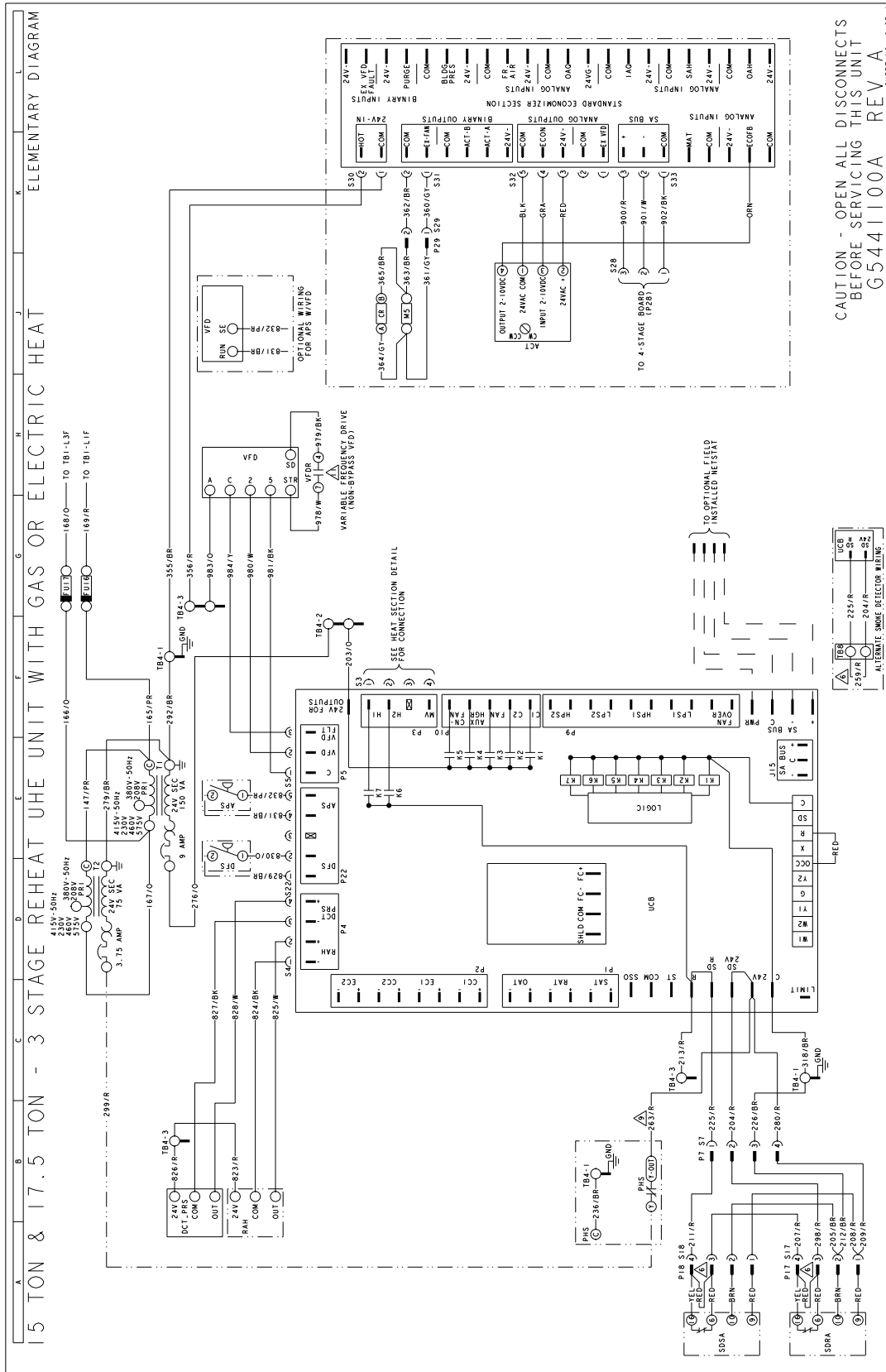

20 ton - 4 stage cooling UHE unit with gas or electric heat

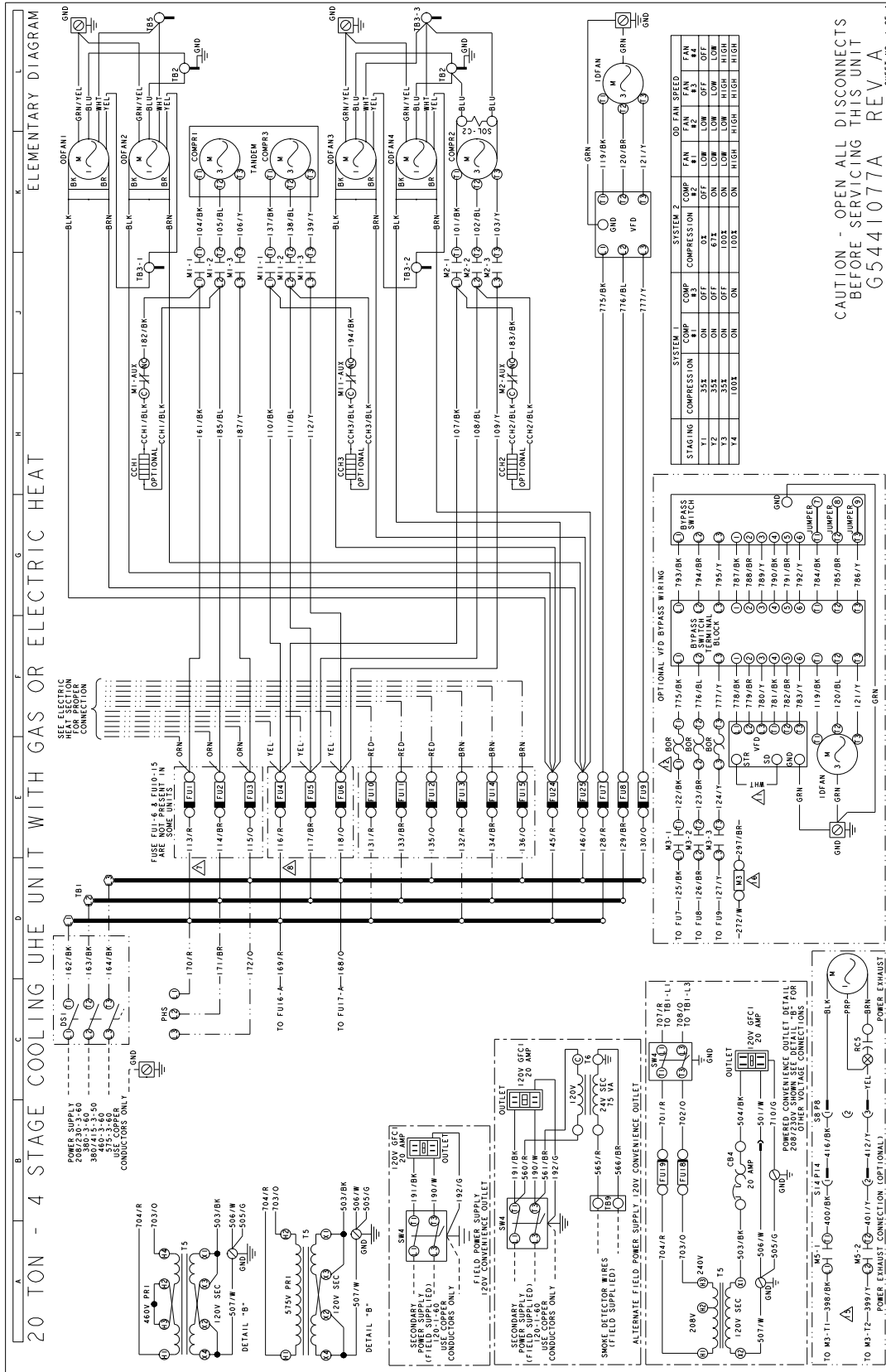

20 ton - 4 stage cooling UHE unit with gas or electric heat (continued)

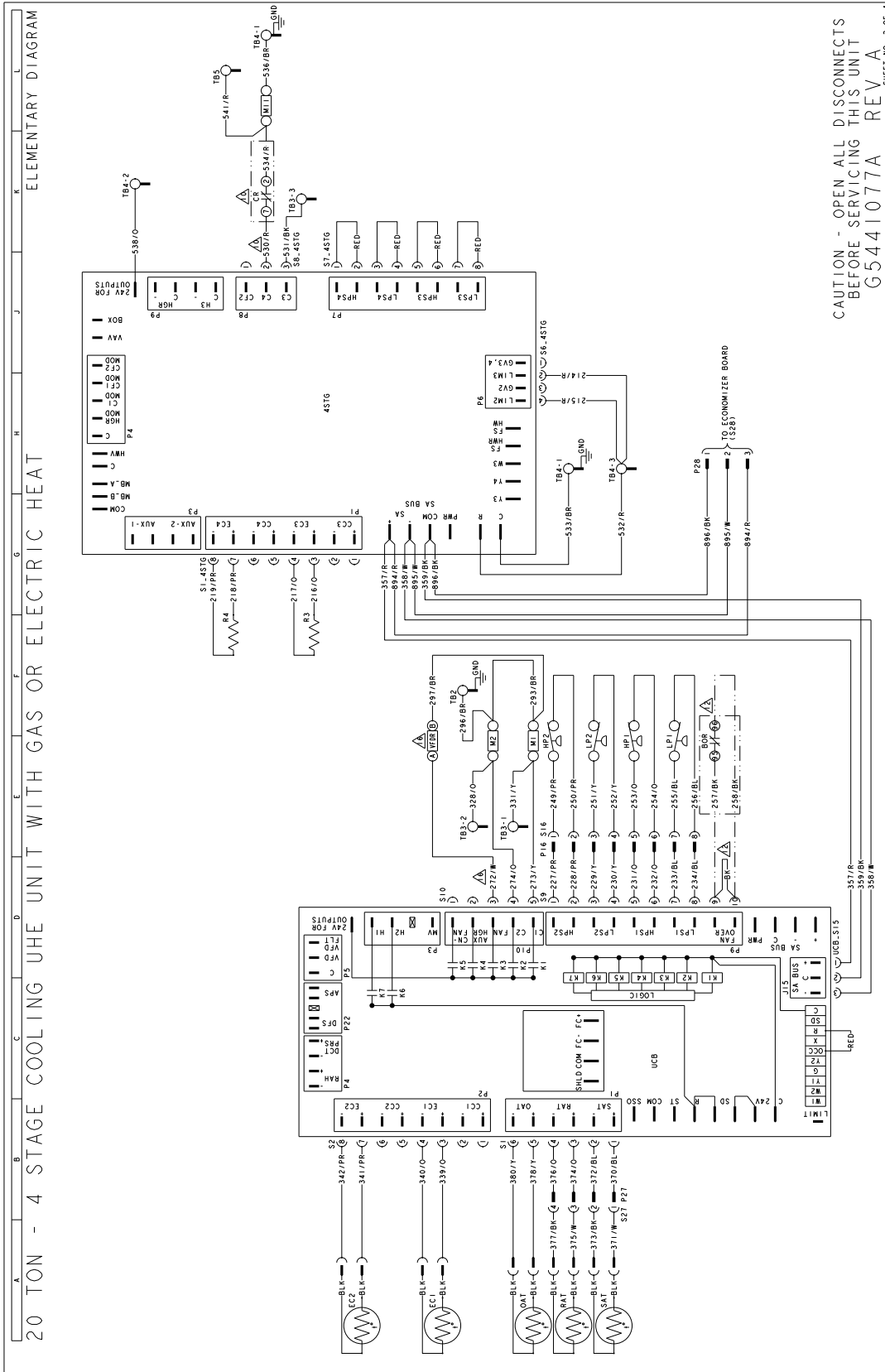

20 ton - 4 stage cooling UHE unit with gas or electric heat (continued)

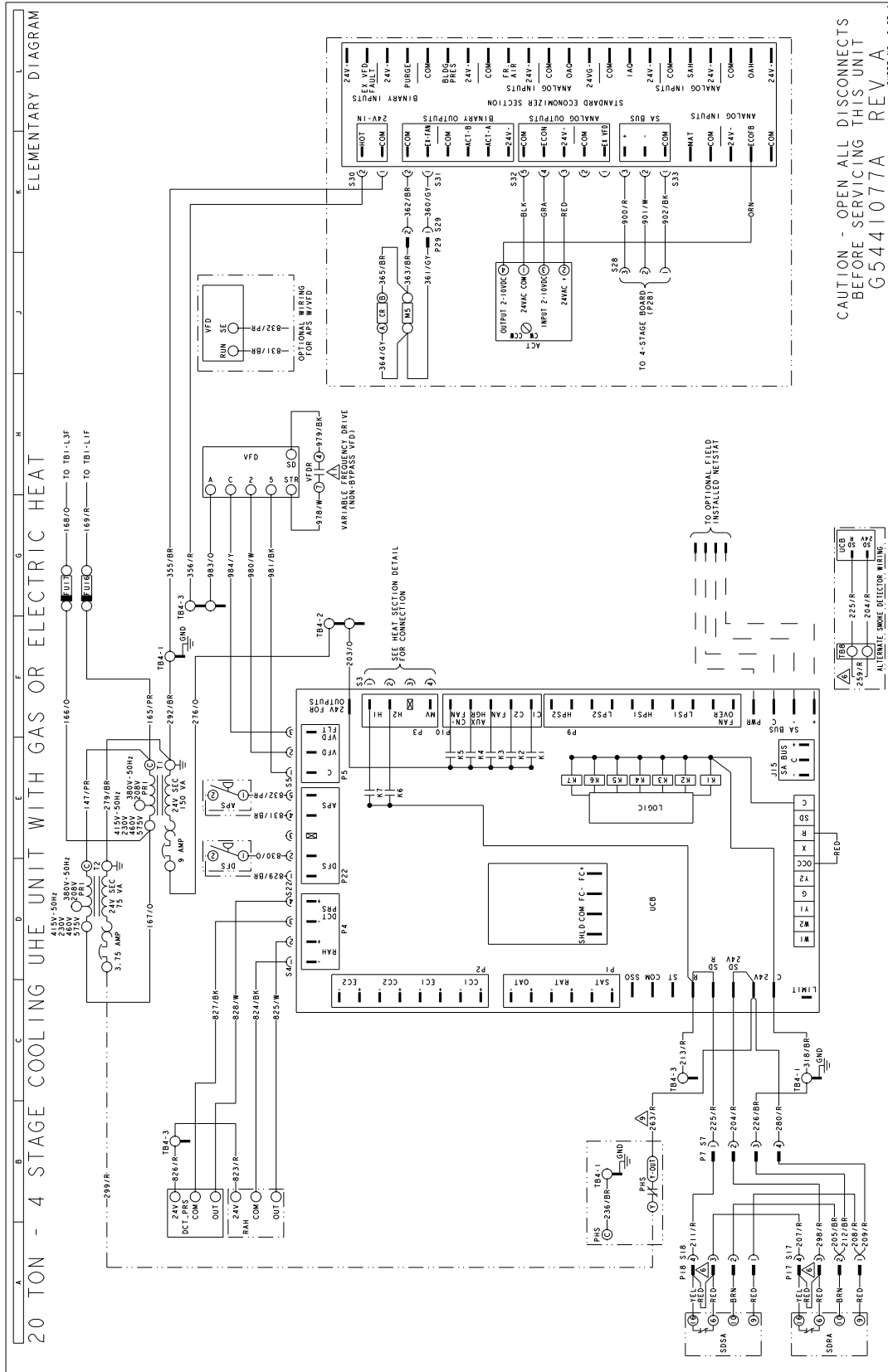

20 ton - 4 stage reheat UHE unit with gas or electric heat

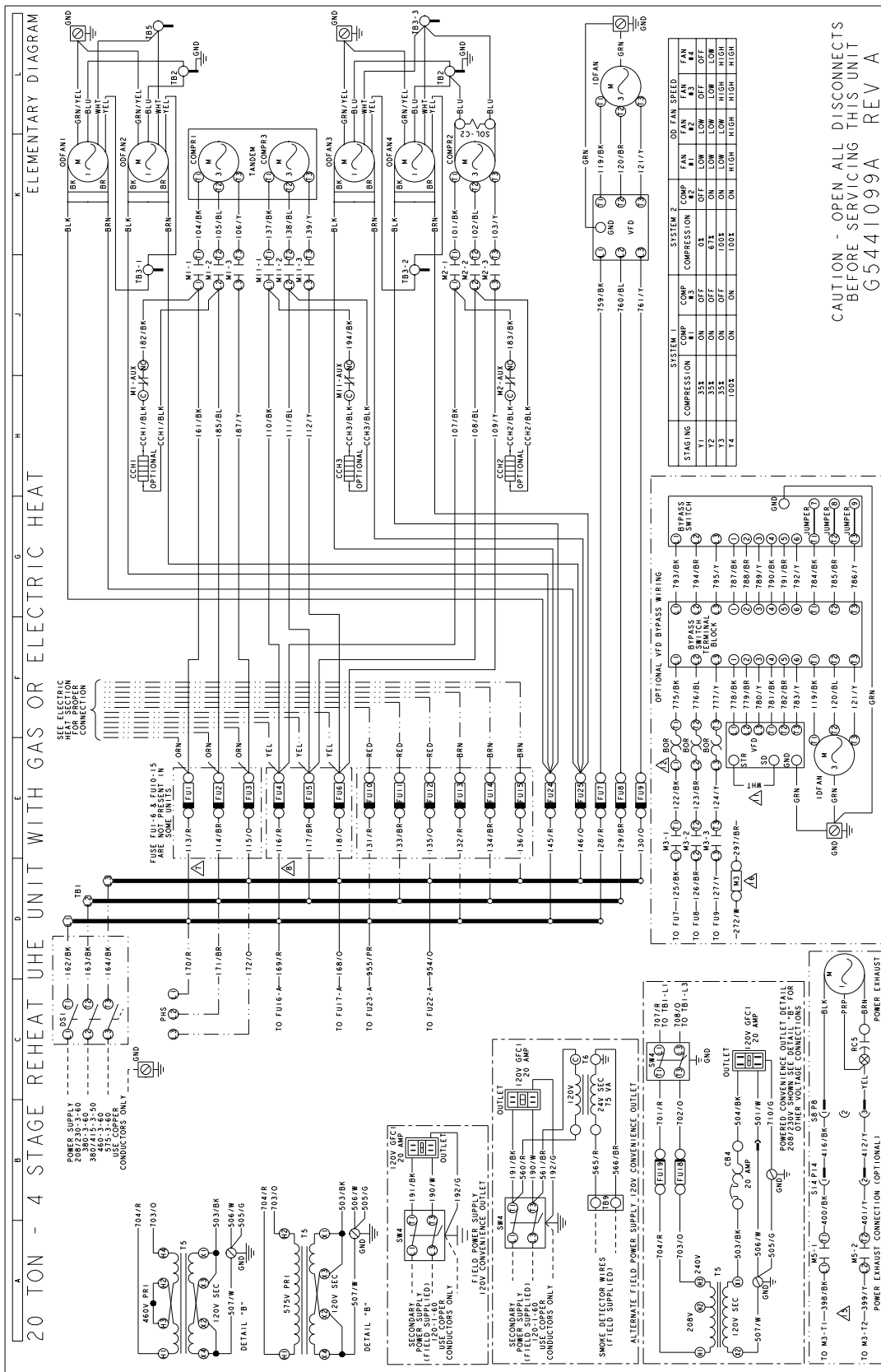

20 ton - 4 stage reheat UHE unit with gas or electric heat (continued)

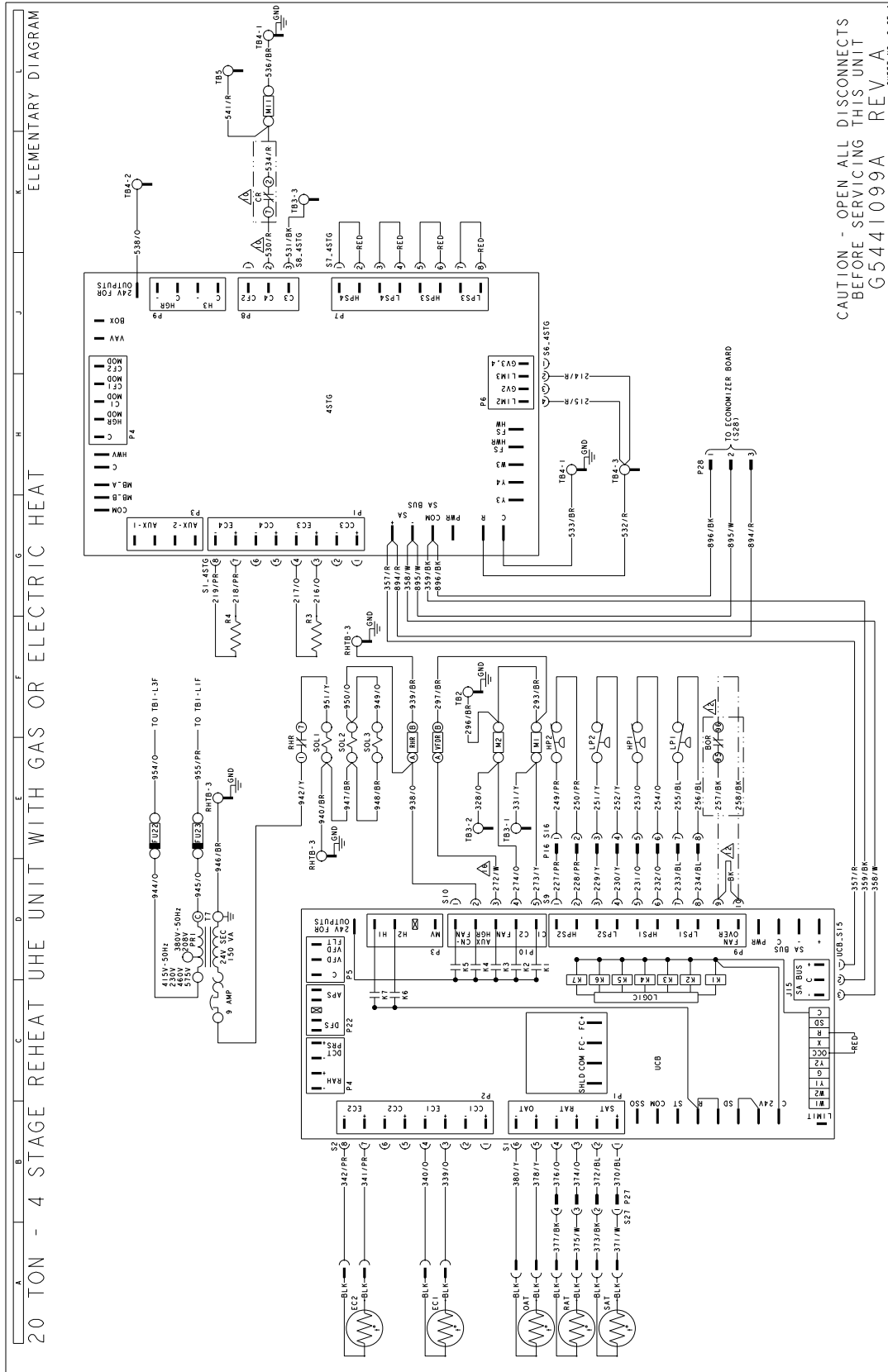

20 ton - 4 stage reheat UHE unit with gas or electric heat (continued)

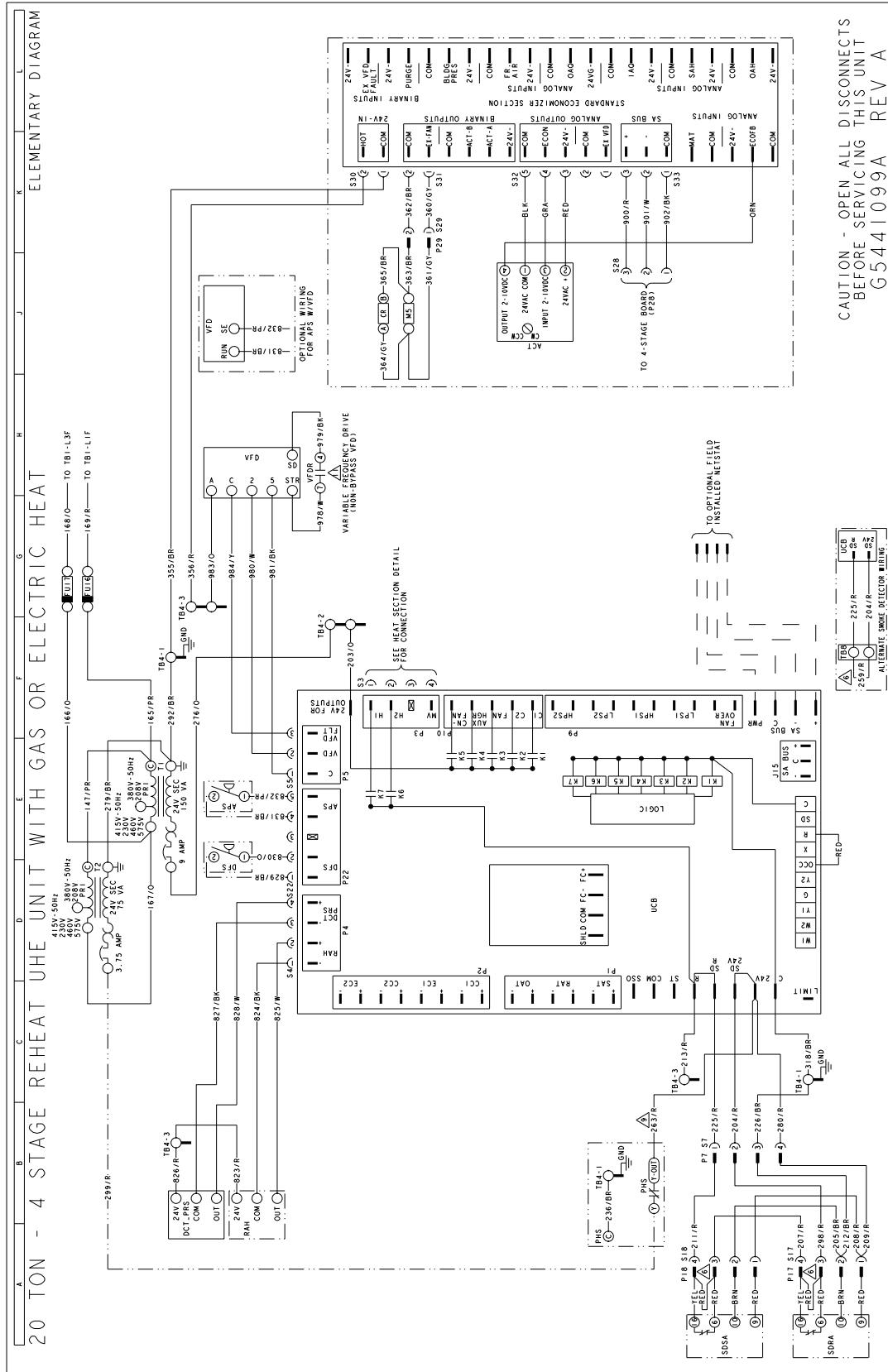

Weights and dimensions

ZT unit 4 point load weight

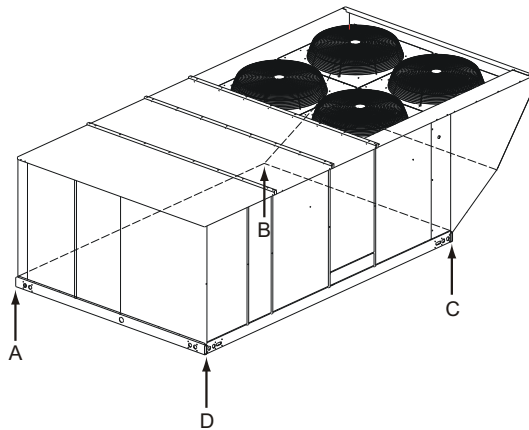

ZT unit 6 point load weight

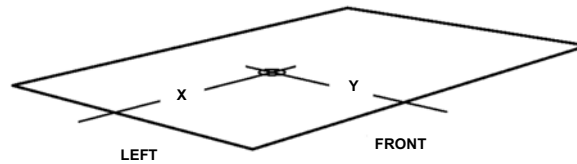
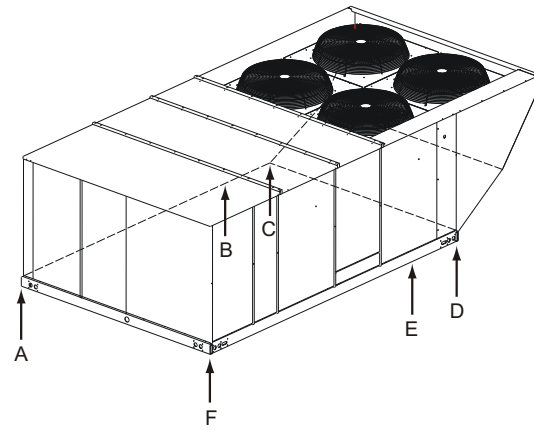

ZT180-276 unit weights

Size (tons)	Model	Weight (lbs.)		Center of gravity		4 point load location (lbs.)				6 point load location (lbs.)					
		Shipping	Operating	X	Y	A	B	C	D	A	B	C	D	E	F
180 (15)	ZT	2605	2600	85.5	43.4	457	770	862	512	281	385	561	628	431	314
210 (17.5)	ZT	2735	2730	85.2	43.6	485	809	898	538	298	407	589	653	452	331
240 (20)	ZT	2860	2855	86.5	45.5	516	896	916	527	315	440	657	671	450	322
276 (23)	ZT	2930	2925	85	43.75	523	868	957	577	322	438	631	695	483	355

ZT180-276 reheat unit weights

Size (tons)	Model	Weight (lbs.)		Center of gravity		4 point load location (lbs.)				6 point load location (lbs.)					
		Shipping	Operating	X	Y	A	B	C	D	A	B	C	D	E	F
180 (15)	ZT	2675	2670	84.8	43	471	777	885	537	290	394	564	642	449	331
210 (17.5)	ZT	2825	2820	84.9	42.9	496	819	938	567	305	415	595	681	474	349
240 (20)	ZT	2990	2985	86	44.5	532	911	973	568	326	452	666	711	482	348
276 (23)	ZT	3040	3035	85.4	43.4	534	897	1005	598	328	450	653	732	504	368

ZT180-276 unit accessory weights

Unit accessory	Weight (lbs.)	
	Shipping	Operating
Economizer	165	160
Power exhaust	90	85
Electric heat ¹	40	40
Gas heat ²	240	240
Double wall	260	260
Motorized damper	150	150
Barometric damper	50	45
Econ./motorized damper rain hood	60	55
Econ./power exhaust rain hood	95	90
Wood skid	220	220
Roof curb	190	185
Hot gas bypass	10	10
Supply fan VFD	See supply fan VFD weights	

1. The weight given is for the maximum heater size available (72KW).
2. The weight given is for the maximum number of tube heat exchangers available (8 tube).

Supply fan VFD weights, in lbs.

Supply fan motor	230V	460V
Without manual bypass		
5.0 hp	25	25
7.5 hp	30	30
10.0 hp	30	30
15.0 hp	30	30
With manual bypass		
5.0 hp	30	30
7.5 hp	35	35
10.0 hp	35	35
15.0 hp	40	35

Unit dimensions

ZT unit dimensions front view

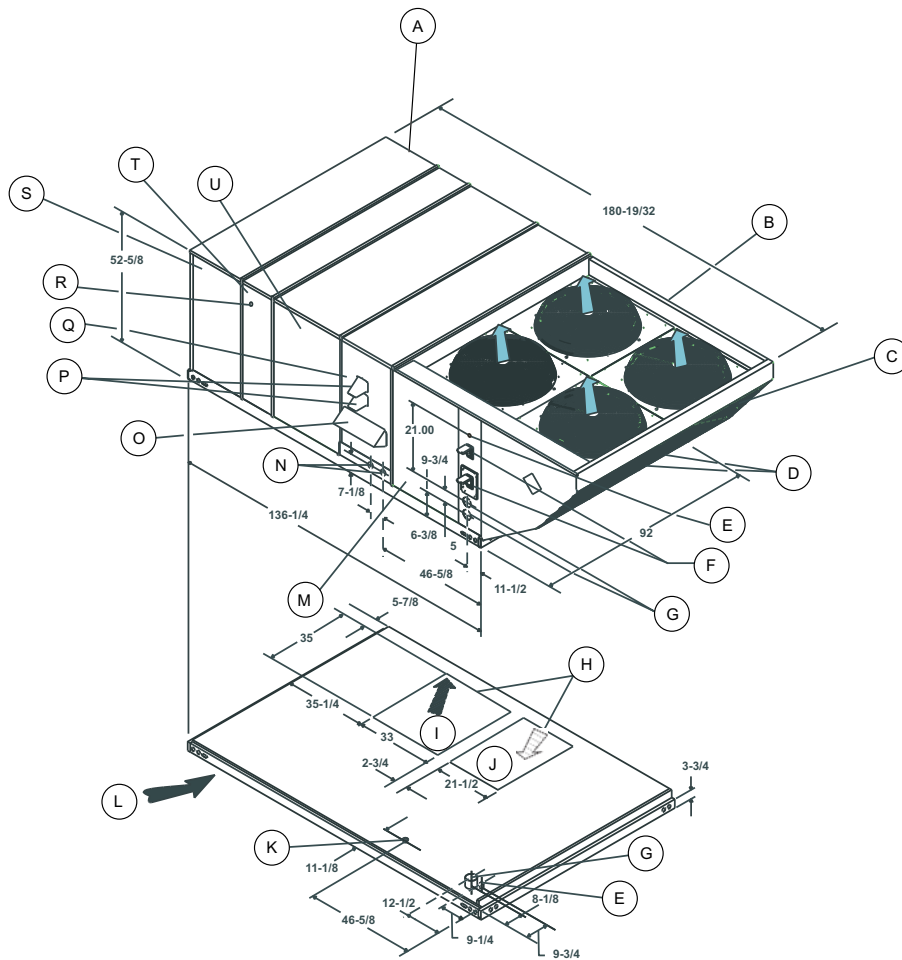

Item	Description
A	Economizer/motorized damper fixed outdoor intake air and power exhaust rain hoods. See detail Y
B	Compressor access
C	Coil guard kit
D	Condenser coils
E	Control wiring entry (A)
F	Disconnect switch location
G	Power wiring entry (B)
H	Bottom supply and return air openings ¹
I	Return air
J	Supply air
K	Gas supply entry (D)

Item	Description
L	Unit base rails: shown separately to show the bottom duct openings and power and gas piping location
M	Control box access location
N	Gas supply entry (C)
O	Combustion air inlet hood
P	Vent air outlet hoods
Q	Gas or electric heat access
R	Dot plug for pressure drop reading
S	Blower compartment access (auxiliary)
T	Blower motor access and location of optional VFD bypass
U	Blower access and location of optional VFD

1. For curb mounted units, refer to the curb hanger dimensions of the curb for the size of the supply and return air duct connections.

Utilities entry

Hole	Opening size diameter	Used for	
A	1-1/8 in. KO	Control wiring	Front
	3/4" NPS (Fem.)		Bottom
B	3-5/8 in. KO	Power wiring	Front
	3 in. NPS (Fem.)		Bottom
C	2-3/8 in. KO	Gas piping (Front) ¹	
D	1-11/16 in. hole	Gas piping (Bottom) ^{1,2}	

1. One-inch gas piping NPT required.

2. Opening in the bottom to the unit can be located by the slice in the insulation.

Note: All entry holes should be field sealed to prevent rain water entry into the building.

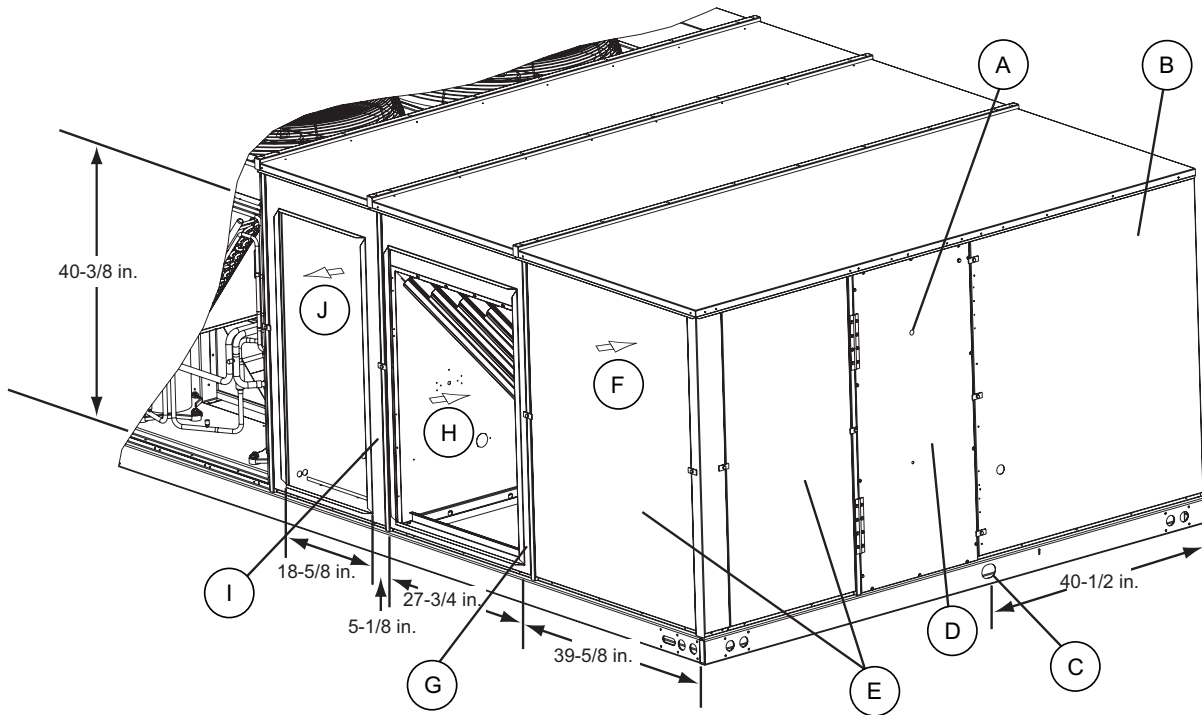
ZT unit dimensions rear view

Item	Description
A	Dot plug for pressure drop reading
B	Evaporator section
C	1-inch NPT female cond. drain connection
D	Filter access
E	Outdoor air compartment access

Item	Description
F	Outdoor air
G	Return air access
H	Return air
I	Supply air access
J	Supply air

The image above shows the unit dimensions for the rear view. The dimensions listed are for side duct flange opening. See field accessories for the side duct flange kit.

Note: Units are shipped with the bottom duct openings covered. An accessory flange kit is available for connecting side ducts.

For a bottom duct application, complete the following steps.

1. Remove the side panels from the supply and return air compartments to gain access to the bottom supply and return air duct covers.
2. Remove and discard the bottom duct covers.
Duct openings are closed with sheet metal covers except when the unit includes a power exhaust option. The covering consists of a heavy black paper composition.
3. Replace the side supply and return air compartment panels.

For a side duct application, complete the following steps.

1. Replace the side panels on the supply and return air compartments with the accessory flange kit panels.
2. Connect ductwork to the flanges on those panels.

ZT unit dimensions rain hood

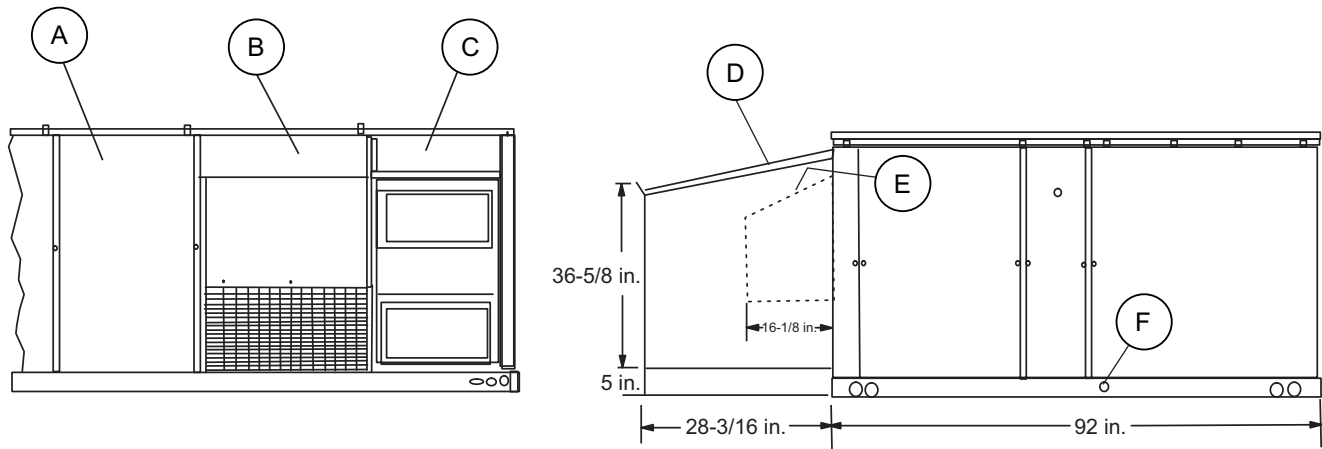

Rear view	
Item	Description
A	Supply air compartment
B	Power exhaust rain hood on the return air compartment
C	Economizer/motorized damper rain hood on the outdoor air compartment

LH view	
Item	Description
D	Economizer/motorized damper and power exhaust rain hood
E	Fixed outdoor air intake hood on the return air compartment
F	1 in. condensate drain. You must trap the drain.

The image above shows detail Y of the unit with rain hoods installed.

ZT180-276 unit clearances

Direction	Distance (in.)	Direction	Distance (in.)
Top ¹	72 with 36 maximum horizontal overhang (for condenser air discharge)	Right	36
Front	36	Bottom ²	0
Rear	24 (without an economizer)	Left	24 (without an economizer)
	49 (with an economizer)		36 (with an economizer) ³

- Units must be installed outdoors. Over hanging structure or shrubs should not obscure condenser air discharge outlet.
- Units may be installed on combustible floors made from wood or class A, B or C roof covering materials.
- If economizer is factory installed, the unassembled rain hood must be removed from its ride along position in front of the evaporator coil, or in the outdoor air compartment, prior to final installation.

Elec/elec model clearances

Units and ductwork are approved for zero clearance to combustible material when equipped with electric heaters.

Gas/elec model clearances

A 1 in. clearance must be provided between any combustible material and the supply air ductwork for a distance of 3 feet from the unit.

The products of combustion must not be allowed to accumulate within a confined space and recirculate.

Locate the unit so that the vent air outlet hood position meets the following conditions.

- It is at least three feet above any force air inlet located within 10 horizontal feet (excluding those integral to the unit).
- It is at least four feet below, four horizontal feet from, or one foot above any door or gravity air inlet into the building.
- It is at least four feet from electric and gas meters, regulators and relief equipment.

Unit accessory dimensions

ZT180-276 roof curb

The following image shows the ZT180-276 roof curb. The supply and return air and duct support rails shown are typical for bottom duct applications. For the location of horizontal duct applications see *ZT unit dimensions rear view* on page 66. The following table lists the duct sizes.

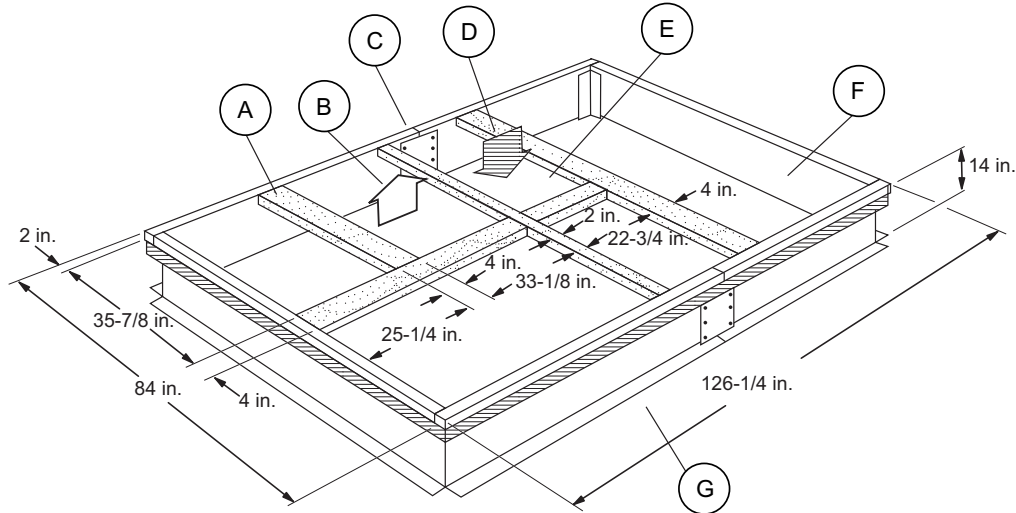

Item	Description
A	Duct support rails
B	Return air
C	Back of the unit
D	Supply air

Item	Description
E	Min. roof opening 39-7/8 in. wide x 61-7/8 in. long
F	Outdoor coil, end of the unit
G	Front of the unit

Duct sizes

Duct	Size
Supply air	22-1/2 in. x 35-5/8 in.
Return air	32-7/8 in. x 35-5/8 in.

ZT180-276 roof curb duct openings

The following image shows a front view with joist supports.

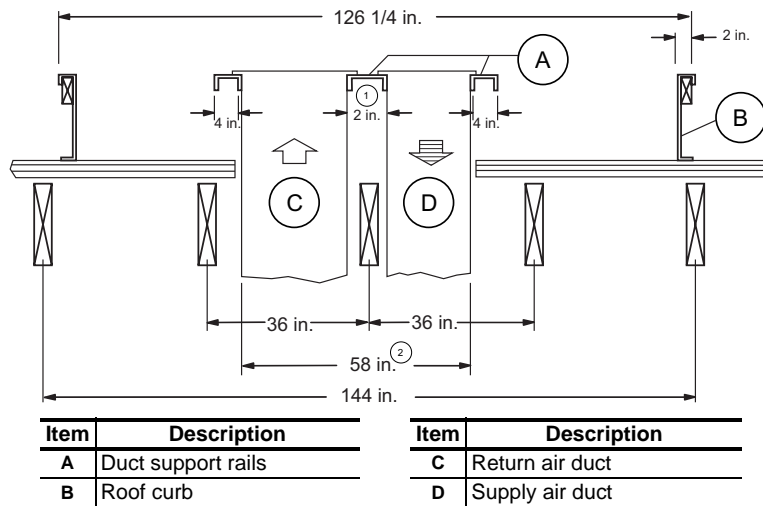

Item	Description
A	Duct support rails
B	Roof curb

Item	Description
C	Return air duct
D	Supply air duct

1. The 2 in. space between the ducts allows for jumping an existing roof joist.
2. The 58-1/2 in. overall dimension of the ducts allows ductwork penetration between roof joists that are spaced on 72 in. centers.

Note: Ducts can be installed into the curb from the roof. All electrical and gas line connections can be made inside the curb.

ZT180-276 cut away of roof curb

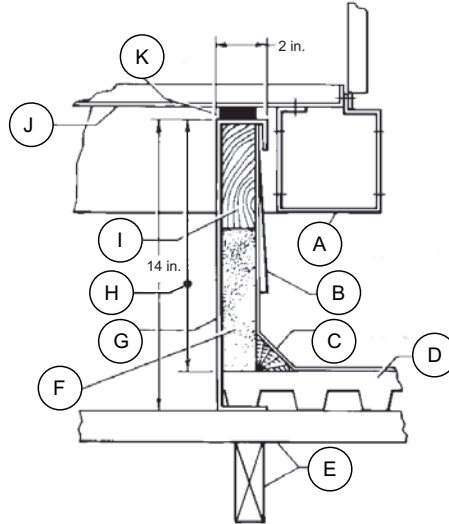

Item	Description
A	Unit base rails
B	Counterflashing
C	Cant strip
D	Insulation and roofing material
E	Roof deck and support structure
F	Insulation

Item	Description
G	Curb frame
H	8 in. minimum above finished roof
I	Wood nailer
J	Unit base
K	3/4 in. x 1-1/4 in. wide gasketing for curb frame and all duct support surfaces

ZT180-276 typical installation

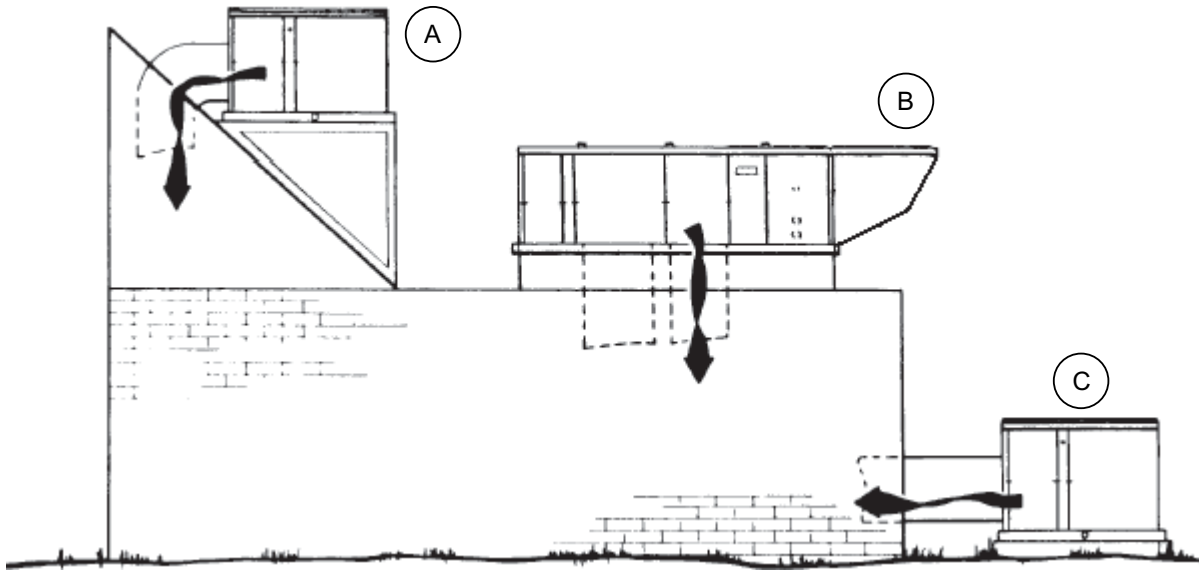

Item	Description
A	Roof jack installation
B	Roof curb installation
C	Slab on ground installation

Subject to change without notice. Printed in U.S.A.
Copyright © 2018 by Johnson Controls, Inc. All rights reserved.

5566232-YTG-A-0119
Supersedes: Nothing

York International Corporation
5005 York Drive
Norman, OK 73069